

**CHUBBY[®]
GORILLA**

ENGINEERED FOR A PURPOSE[™]

2026

PRODUCT CATALOG

CHUBBYGORILLA.COM



TABLE OF CONTENTS

THE COMPANY

| | | | |
|------------------------|----|-------------------------------------|----|
| About Us & Our Mission | 03 | History of Innovation and Execution | 05 |
| Global Footprint | 04 | | |

BOTTLES

| | | | |
|--------------|----|-----------------------------|----|
| Introduction | 07 | Measurement | 16 |
| Dispensing | 08 | Colors / Sizes / Capacities | 19 |
| Beverage | 11 | | |

CONTAINERS

| | | | |
|------------------------|----|-----------------------------|----|
| Introduction | 22 | Wide Mouth | 28 |
| Containers with Liners | 23 | Devices | 32 |
| Thick Wall | 26 | Colors / Sizes / Capacities | 35 |

POUCH CONTAINERS

| | | | |
|--------------------|----|-----------------------------|----|
| Introduction | 36 | High Capacity | 41 |
| Single Compartment | 37 | Colors / Sizes / Capacities | 43 |
| Dual Compartment | 39 | | |

TUBES

| | | | |
|--------------|----|-----------------------------|----|
| Introduction | 44 | PopCap | 50 |
| Straight | 45 | Colors / Sizes / Capacities | 52 |
| Tapered | 48 | | |

KEY FEATURES GLOSSARY

| | |
|--------------|----|
| Introduction | 53 |
|--------------|----|

CUSTOM SOLUTIONS

| | | | |
|------------------------------------|----|---|----|
| Introduction | 59 | Custom Finishes I | 61 |
| Custom Finishes I | 60 | <i>Bottle/Tube/Container</i> | |
| <i>Outer Closure/Inner Closure</i> | | Direct Printing & Labeling and Post-Consumer Recycled Product | 62 |

SOCIAL RESPONSIBILITY

| | |
|--------------|----|
| Introduction | 63 |
| What We Do | 64 |





ABOUT US

OUR COMPANY

Chubby Gorilla® was founded in Southern California with one primary goal in mind: Make great products that people love using. Everyday, that simple goal informs every decision we make. From the unique design to the high-quality materials that we use in our products, our team works tirelessly to create aesthetically unique products that meet the consumer's needs. Chubby Gorilla® thrives on innovation. We have been awarded over a hundred patents and registered designs, and serve over 100 countries across the globe. These efforts have undoubtedly made Chubby Gorilla® a market leader in providing packaging to the e-liquid market and similarly positioned the company to engage emerging industries.

OUR MISSION

The mission statement of Chubby Gorilla® is “Engineered For A Purpose™” We don't just toss those words around lightly. We know that our customers have many choices, so we take every aspect of that statement very seriously so that consumers continue to demand the high-quality product provided by Chubby Gorilla®. When our customers use one of our products, we want it to be a unique and unparalleled experience.



GLOBAL FOOTPRINT

100+
COUNTRIES SERVED

600+
PATENTS & COMMUNITY DESIGNS

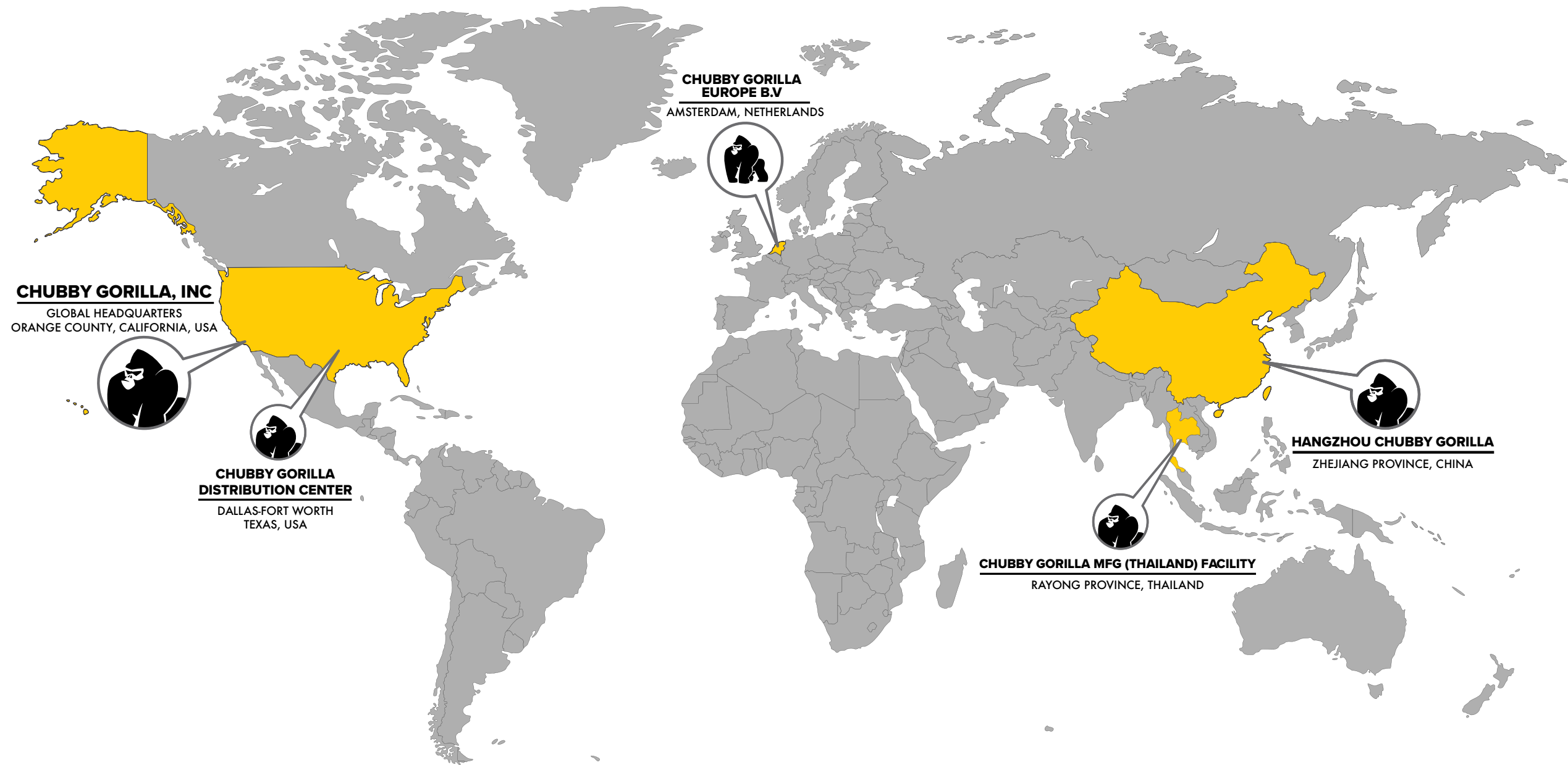

HISTORY OF INNOVATION AND EXECUTION



2014

Founders recognize an opportunity to address the consumer need for e-liquid packaging designed for the purpose.

2015

Opened first Head Quarters in Orange, CA. Company Established. 15 mL LDPE bottle launched, sales into U.S., Canada and Mexico.

2016

30 mL LDPE bottle launched, V1 PET Unicorn Bottle® launched, marking the beginning of an industry transformation.

Head Quarters relocated and addition of warehouse space (6,600 sq ft) in Fullerton, CA.

2017

Opened Chubby Gorilla® China manufacturing facility (75k sq ft) in Zhejiang Province.

Additional warehouse space (4,800 sq ft) added to adjacent existing facility in California Head Quarters in Fullerton, CA.

2018

V3 PET Unicorn Bottle® launched.

Relocated Head Quarters and added warehouse space (34k sq ft) in Santa Fe Springs, CA.

Obtained ISO 9001, ISO 14001 and GMP 110 certifications for Chubby Gorilla® China.

2019

Relocated Head Quarters to Fullerton, CA, and obtained 79k sq ft of warehouse space.

Opened Chubby Gorilla® Europe in the Netherlands (21k sq ft, leased).

Purchased Chubby Gorilla® China facility and renovated, providing 396.4k sq ft of manufacturing space.

2020

Launched sales of Aviator® containers and tubes, packaging designed for the plant wellness end markets.

Filed a tobacco product master file with the FDA.

2021

Constructed additional external office building (8,600 sq ft) at Chubby Gorilla® China.

Obtained ISO 9001 certification at Fullerton, CA facility.

2022

Constructed 75k sq ft expansion at Chubby Gorilla® China, providing a total of 480k sq ft manufacturing space.

GMP 210 and 211 certifications for Chubby Gorilla® China.

2023

Opened Fort Worth, Texas warehouse and office with 54k sq ft warehouse space.

Launched Spiral containers, tubes, and bottles.
Launched Unicorn Bottle® with Reducers.

2024

European Head Quarters relocated to expand to 60k sq ft of warehouse space in Amersfoort, Netherlands.

Obtained ISO 15378 for Chubby Gorilla® China.

Launched Aviator® Functional Beverage Bottles, Pouch Containers, and Spiral® Dosing Cups.

2025

Opened Chubby Gorilla® Manufacturing facility in Thailand 20k sq ft.

Launched X3 Pouch Container.

HISTORY OF INNOVATION AND EXECUTION

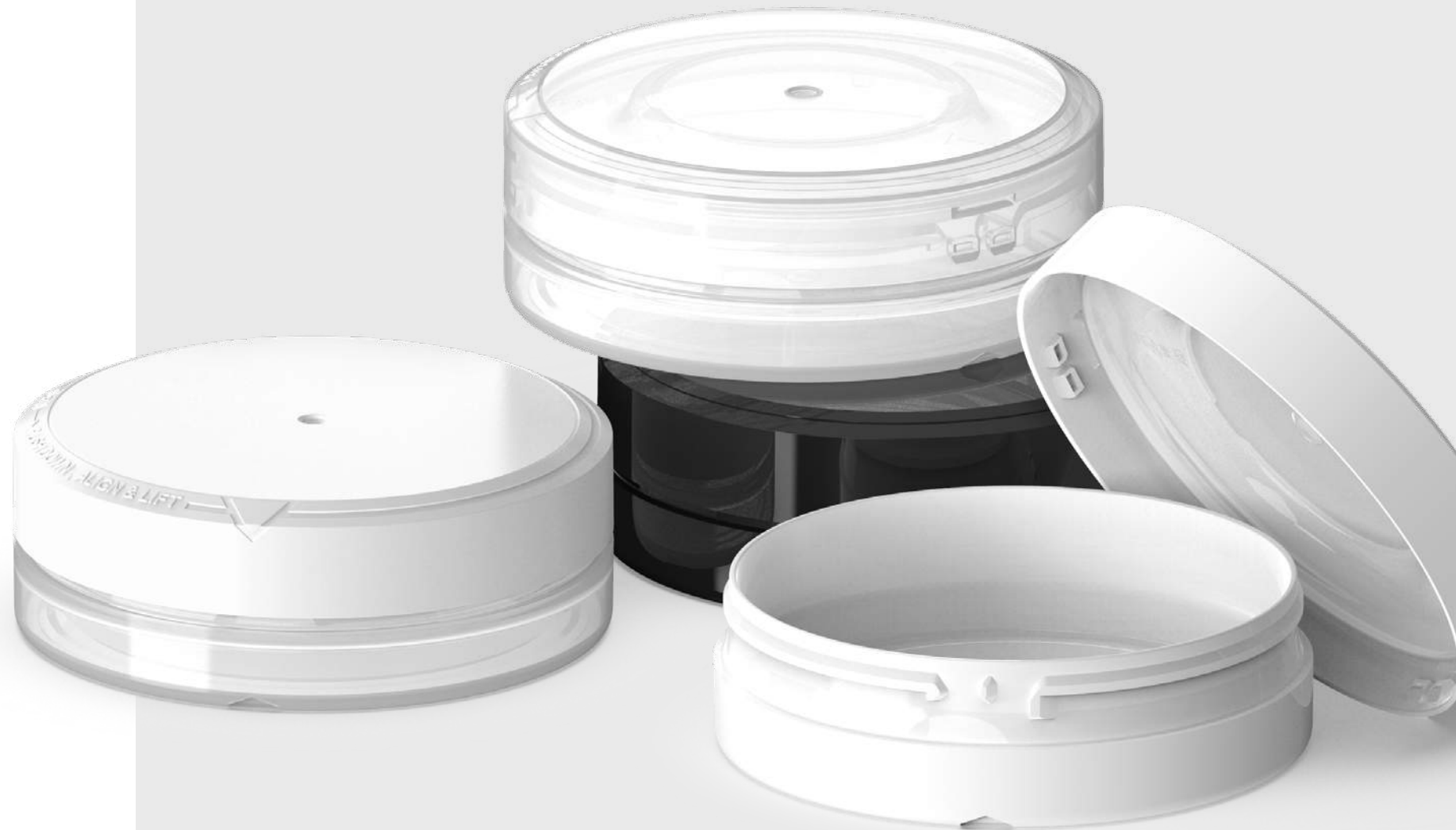



BOTTLES

DISPENSING / BEVERAGE / MEASUREMENT

Chubby Gorilla® provides a comprehensive range of containers designed specifically for solid goods and devices. Each container is engineered with purpose-built features, such as integrated liners, fastened tamper-evident bands, and child-resistant closures, to help deliver a reliable, consistent consumer experience. With this combination of dependable performance and distinctive aesthetics, Chubby Gorilla® helps brands stand out while ensuring the compliance their products deserve.



DISPENSING BOTTLES

UNICORN BOTTLE®
UNICORN BOTTLE® WITH REDUCERS

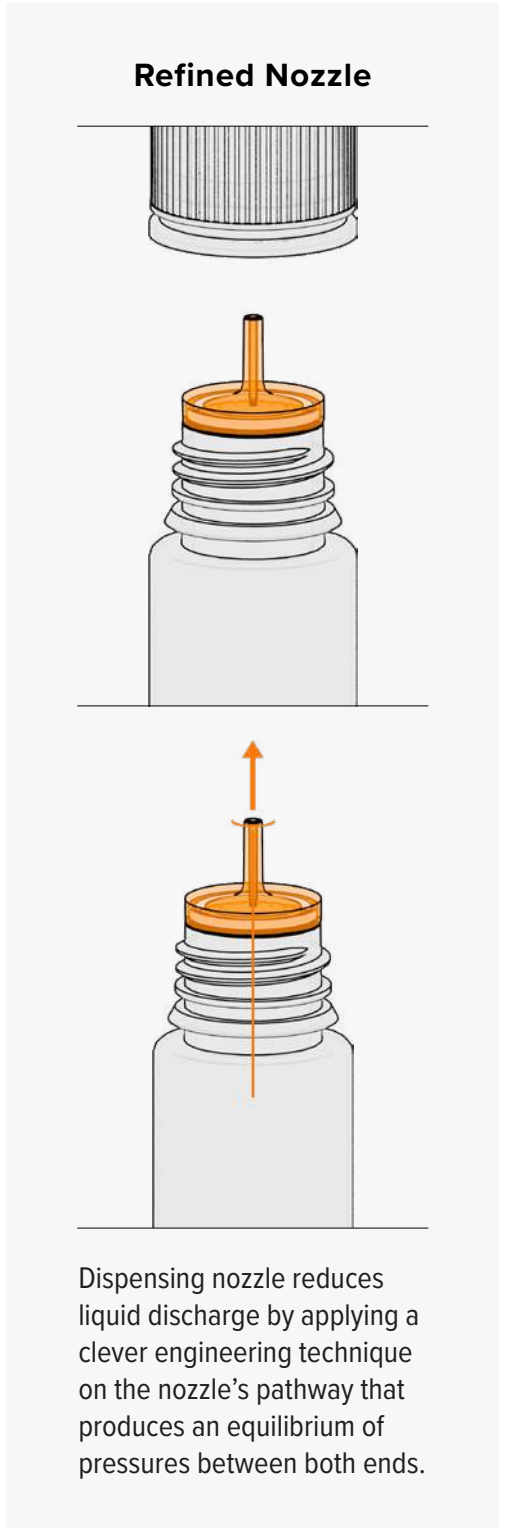
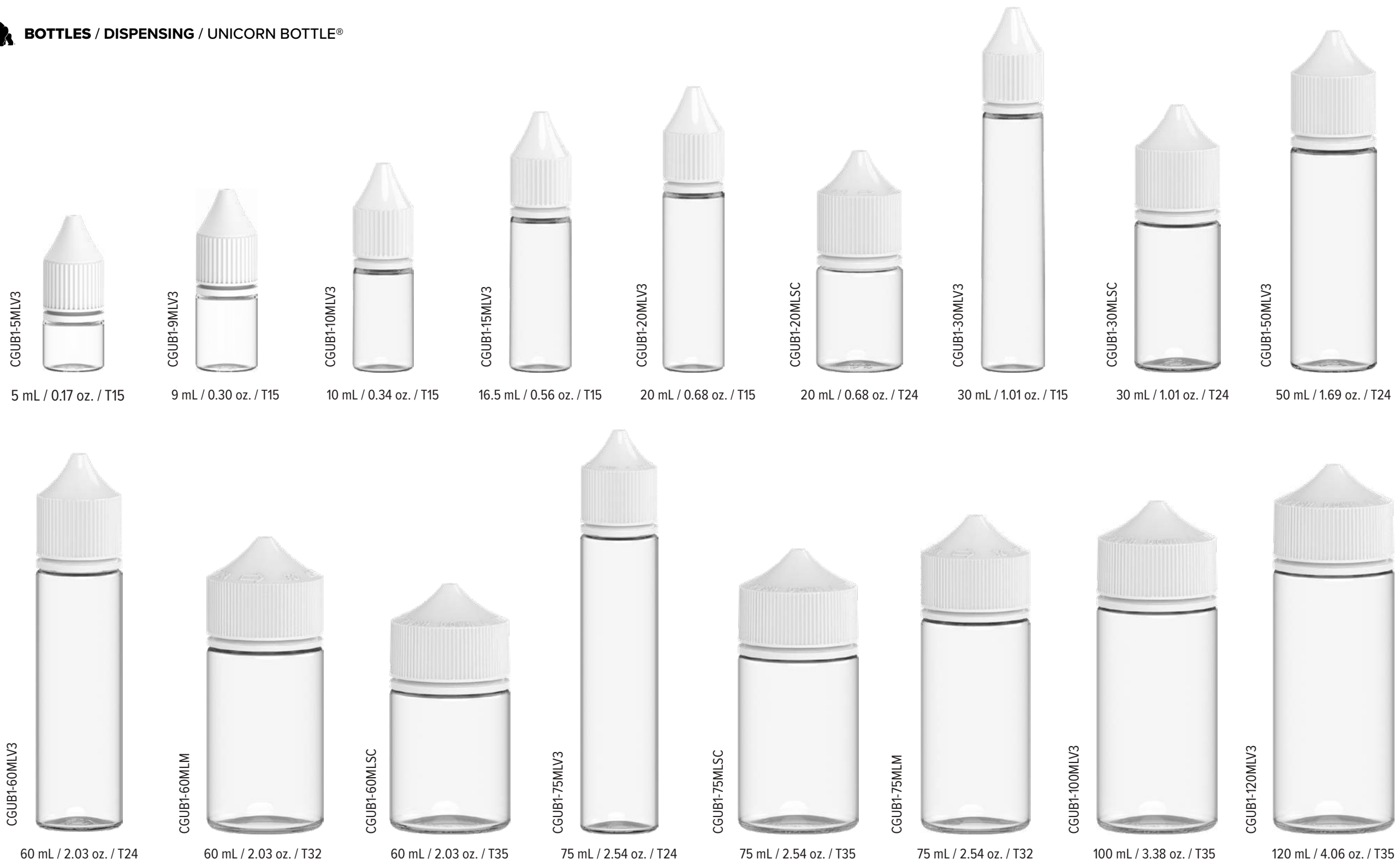

UNICORN BOTTLE®

Available Sizes

5 mL | 9 mL | 10 mL | 16.5 mL | 20 mL | 20 mL STUBBY™ | 30 mL | 30 mL STUBBY™ | 50 mL | 60 mL | 60 mL MINI | 60 mL STUBBY™ | 75 mL | 75 mL STUBBY™ | 75 mL MINI | 100 mL | 120 mL

KEY FEATURES [LEARN MORE](#)

- All-In-One SmartCap
- Child-Resistant Closure
- Liquid Leak-Blocker
- Fastened Tamper-Evident Band
- HoverGLIDE Rotational Suspension Closure
- Pinch A Drip, Squeeze A Flow
- Refined Narrow Drip Tip With Easy-Flow Dispensing
- Designed & Engineered In California, USA
- Protected by Design Patent and/or Design Registration and Additional Patents Pending
- Embossed with Proprietary, Signature Gorilla Logo as a Stamp of Absolute Quality and Authenticity

*Click 'Learn More' to read more details of the Key Features

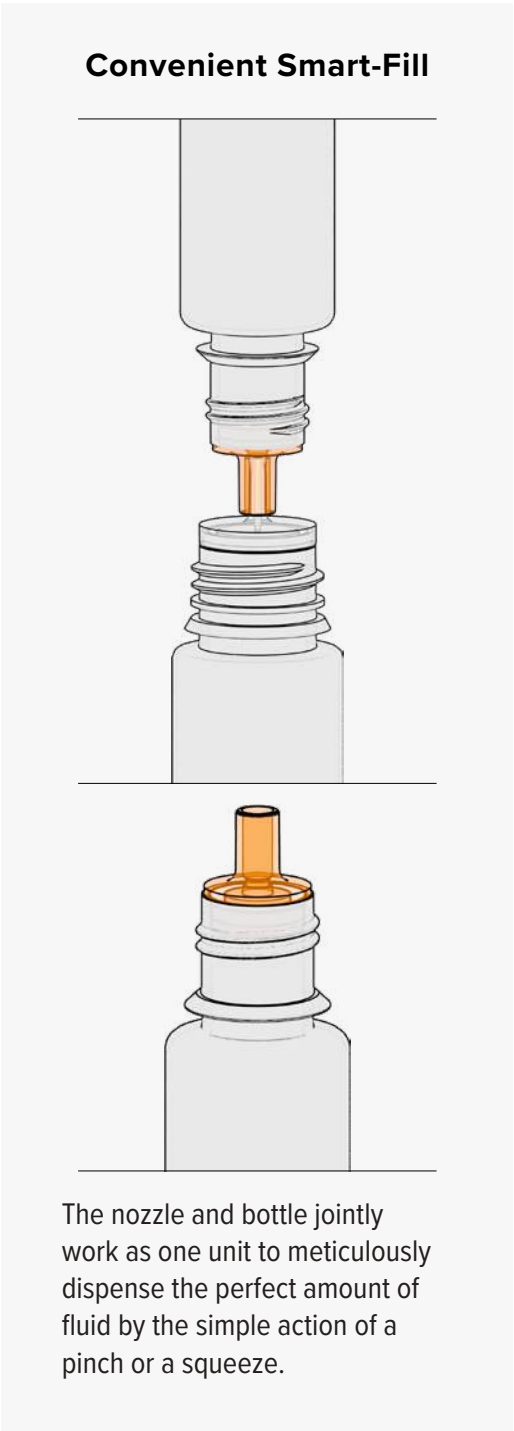
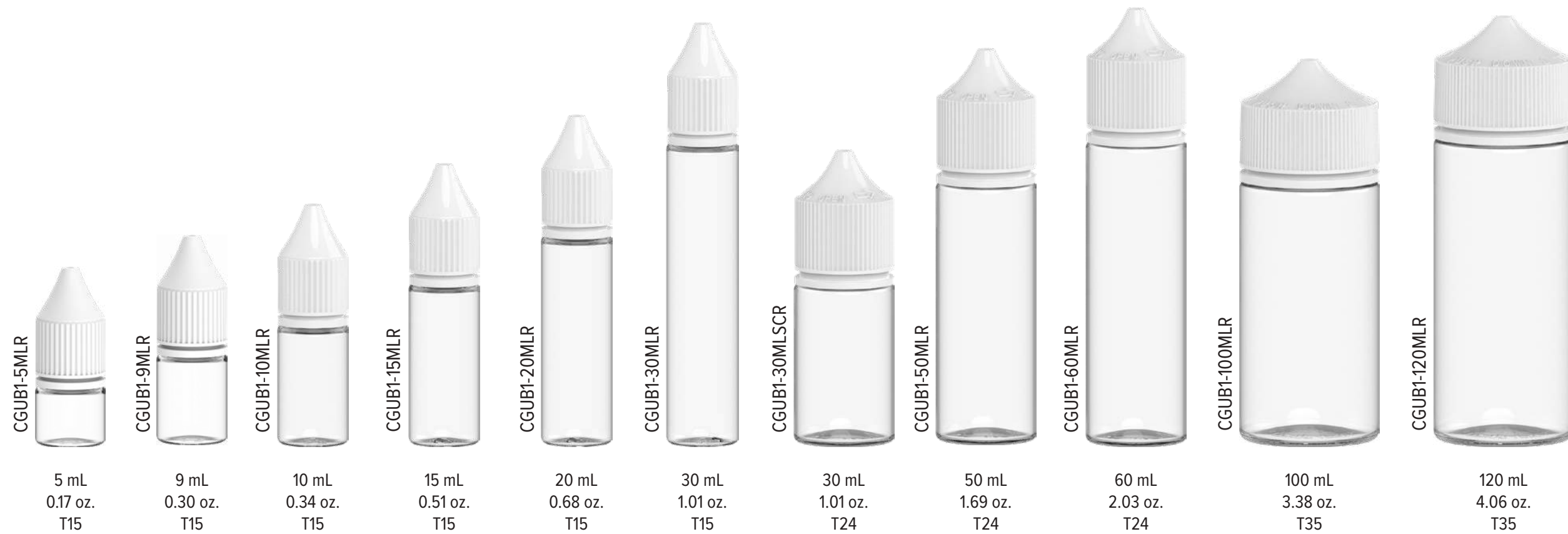

UNICORN BOTTLE® WITH REDUCER

Available Sizes

5 mL | 9 mL | 10 mL | 15 mL | 20 mL | 30 mL | 30 mL STUBBY™ | 50 mL | 60 mL | 100 mL | 120 mL

KEY FEATURES [LEARN MORE](#)

- All-In-One SmartCap
- HoverGLIDE Rotational Suspension Closure
- Fastened Tamper-Evident Band
- Designed & Engineered In California USA
- Convenient Smart-Fill
- Liquid Leak-Blocker
- Protected by Design Patent and/or Design Registration and Additional Patents Pending
- Embossed with Proprietary, Signature Gorilla Logo as a Stamp of Absolute Quality and Authenticity



BEVERAGE BOTTLES

- SPIRAL® SHOT BOTTLES
- SPIRAL® BOTTLES
- AVIATOR® SHOT BOTTLES
- AVIATOR® BOTTLES



CGSSB1-30MLSC
30 mL / 1.01 oz. / T28



CGSSB1-60MLM
60 mL / 2.03 oz. / T28



CGSSB1-60ML
60 mL / 2.03 oz. / T28



CGSSB1-100MLM
100 mL / 3.38 oz. / T28

Friction-Fit Closure

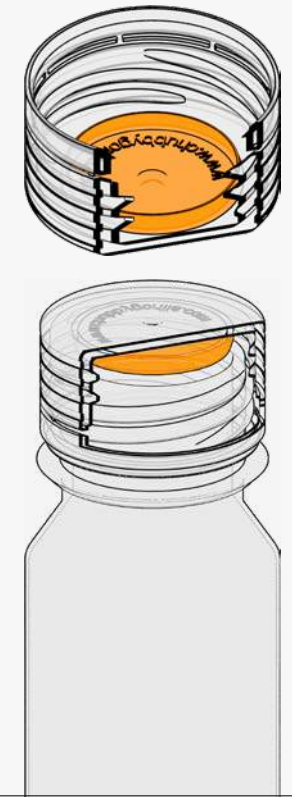

The SmartCap uses a friction closure that automatically creates a seal with the bottle neck, to support liquid leaks from occurring.

SPIRAL® SHOT BOTTLES

Available Sizes
30 mL STUBBY™ | 60 mL MINI |
60 mL | 100 mL MINI

Introducing the all new Spiral® Non-Child Resistant Shot Bottles, designed for the functional beverage industry. Each bottle features a tamper-evident band for product integrity and a friction-fit closure to help prevent against liquid leaks, ensuring both reliability and consumer confidence.

KEY FEATURES [LEARN MORE](#)

- All-In-One Smartcap
- Contoured Groove Surface
- Fastened Tamper-Evident Band
- Friction-Fit Closure
- Designed & Engineered In California USA
- Protected by Design Patent and/or Design Registration and Additional Patents Pending
- Embossed with Proprietary, Signature Gorilla Logo as a Stamp of Absolute Quality and Authenticity



CGSB1-10ML
10 mL
0.34 oz.
T15

CGSB1-16.5ML
16.5 mL
0.56 oz.
T15

CGSB1-20ML
20 mL
0.68 oz.
T15

CGSB1-30MLSC
30 mL
1.01 oz.
T24

CGSB1-30ML
30 mL
1.01 oz.
T15

CGSB1-50ML
50 mL
1.69 oz.
T24

CGSB1-60ML
60 mL
2.03 oz.
T24

CGSB1-100ML
100 mL
3.38 oz.
T35

CGSB1-120ML
120 mL
4.06 oz.
T35

Friction-Fit Closure

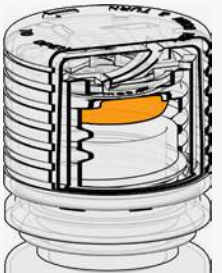
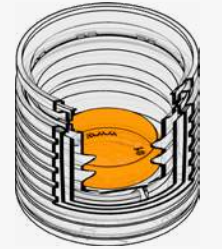

The SmartCap uses a friction closure that automatically creates a seal with the bottle neck, to support liquid leaks from occurring.

SPIRAL® BOTTLES

Available Sizes: Bottles
10 mL | 16.5 mL | 20 mL | 30 mL | 30 mL STUBBY™ |
50 mL | 60 mL | 100 mL | 120 mL

Chubby Gorilla's Spiral® Bottles offer optimal solutions for a wide range of beverages and liquid fluids. Engineered with a friction-fit closure, our Spiral® Bottles help support liquid leaks from occurring. Available in various sizes, catering not only to liquid storage but also offering a versatile packaging option for multipack products.

KEY FEATURES [LEARN MORE](#)

- All-In-One Smartcap
- Child-Resistant Closure
- Rotational Suspension Closure
- Fastened Tamper-Evident Band
- Friction-Fit Closure
- Contoured Groove Surface
- Designed & Engineered In California USA
- Protected by Design Patent and/or Design Registration and Additional Patents Pending
- Embossed with Proprietary, Signature Gorilla Logo as a Stamp of Absolute Quality and Authenticity



CGASB1-30MLSC
30 mL / 1.01 oz. / T28



CGASB1-60MLM
60 mL / 2.03 oz. / T28



CGASB1-60ML
60 mL / 2.03 oz. / T28



CGASB1-100MLM
100 mL / 3.38 oz. / T28

Friction-Fit Closure

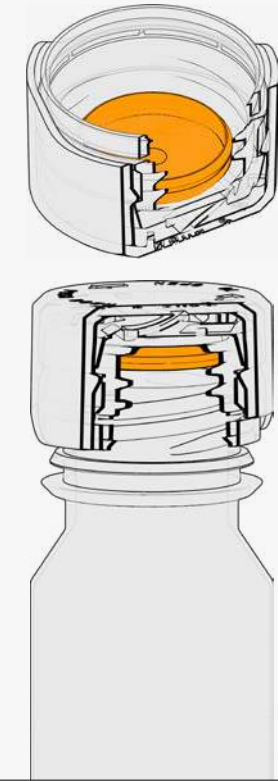

The SmartCap uses a friction closure that automatically creates a seal with the bottle neck, to support liquid leaks from occurring.

AVIATOR® SHOT BOTTLES

Available Sizes
30 mL STUBBY™ | 60 mL MINI |
60 mL | 100 mL MINI

Aviator® Shot Bottles offer the ideal packaging solution for concentrate, supplement, and nootropic beverages. Expertly engineered, these bottles introduce a fresh, innovative aesthetic to a beverage market craving alternatives to standard off-the-shelf packaging. Featuring an integrated child-resistant closure, a fastened tamper-evident band, and a friction-fit closure, Aviator® Shot Bottles are a performance based line of packaging for any beverage industry.

KEY FEATURES [LEARN MORE](#)

- All-In-One Smartcap
- Child-Resistant Closure
(excludes Aviator® Shot Bottle 100 mL)
- Rotational Suspension Closure
- Fastened Tamper-Evident Band
- Friction-Fit Closure
- Designed & Engineered In California USA
- Protected by Design Patent and/or Design Registration and Additional Patents Pending
- Embossed with Proprietary, Signature Gorilla Logo as a Stamp of Absolute Quality and Authenticity



| | | | | | | | | |
|--------------------------|----------------------------|--------------------------|--------------------------|--------------------------|--------------------------|--------------------------|---------------------------|---------------------------|
| CGAB1-10ML | CGAB1-16.5ML | CGAB1-20ML | CGAB1-30ML | CGAB1-30MLSC | CGAB1-50ML | CGAB1-60ML | CGAB1-100ML | CGAB1-120ML |
| 10 mL 0.34 oz. T15 | 16.5 mL 0.56 oz. T15 | 20 mL 0.68 oz. T15 | 30 mL 1.01 oz. T15 | 30 mL 1.01 oz. T24 | 50 mL 1.69 oz. T24 | 60 mL 2.03 oz. T24 | 100 mL 3.38 oz. T35 | 120 mL 4.06 oz. T35 |

Friction-Fit Closure

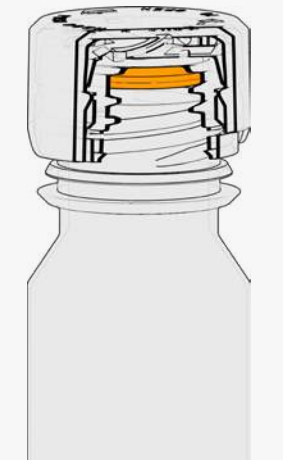
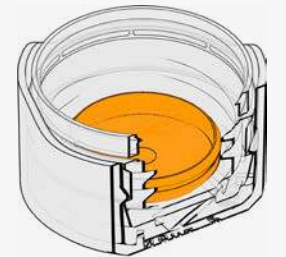

The SmartCap uses a friction closure that automatically creates a seal with the bottle neck, to support liquid leaks from occurring.

**AVIATOR®
BOTTLES**

Available Sizes
10 mL | 16.5 mL | 20 mL | 30 mL | 30 mL STUBBY™ |
50 mL | 60 mL | 100 mL | 120 mL

Aviator® Bottles offer optimal solutions for beverages, and other liquid fluids. Our Aviator® Bottles are constructed with a friction-fit closure to support liquid leaks from occurring. Additionally, Aviator® Bottles come in a variety of sizes to store not only liquids, but multipack products making them a versatile packaging option.

KEY FEATURES [LEARN MORE](#)

- All-In-One Smartcap
- Child-Resistant Closure
- Rotational Suspension Closure
- Fastened Tamper-Evident Band
- Friction-Fit Closure
- 360 Micro-Grip Diamond Surface
- Designed & Engineered In California USA
- Protected by Design Patent and/or Design Registration and Additional Patents Pending
- Embossed with Proprietary, Signature Gorilla Logo as a Stamp of Absolute Quality and Authenticity



MEASUREMENT BOTTLES

AVIATOR® BASE BOTTLES
SPIRAL® DOSING CUPS

CGABB1-250ML



250 mL / 8.45 oz. / T48

CGABB1-500ML



500 mL / 16.90 oz. / T48

CGABB1-1LTR



1 L / 33.81 oz. / T48

Lock-On Dosing Cup

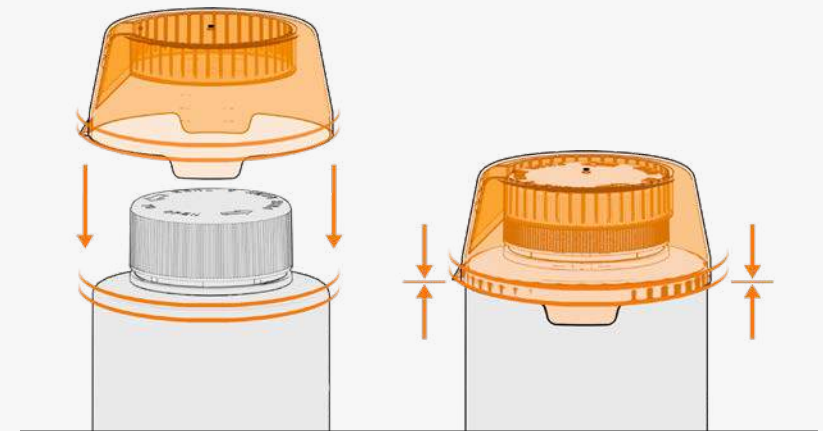

The readily available Dosing Cup is integrated into the closure system.

Dual Volume Dosing Cup

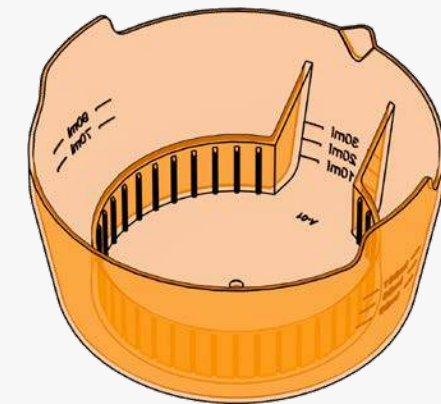

The Dosing Cup features two volume capacity reservoirs for measuring from 5 mL to 10 mL or 50 mL to 200 mL. The flexibility in measuring allows an easier way to custom mix and measure.

AVIATOR® BASE BOTTLES

Available Sizes
250 mL | 500 mL | 1 L

Aviator® Base Bottles offer a unique combination of powder and fluid storage solutions. With an integrated dual volume Dosing Cup for measuring from 5 mL to 10 mL, and 50 mL to 200 mL. The Dosing Cup is ready whether at home or on the go.

KEY FEATURES [LEARN MORE](#)

- All-In-One Smartcap
- Child-Resistant Closure
- Lock-On Dosing Cup
- Rotational Suspension Closure
- Fastened Tamper-Evident Band
- Gapless Surface-Seal Closure
- Dual Volume Dosing Cup
- Designed & Engineered In California USA
- Protected by Design Patent and/or Design Registration and Additional Patents Pending
- Embossed with Proprietary, Signature Gorilla Logo as a Stamp of Absolute Quality and Authenticity



CGSDCUP5-9ML-CNL
9 mL / 0.30 oz.



CGSDCUP5-20ML-CNL
20 mL / 0.68 oz.



CGSDCUP5-40ML-CNL
40 mL / 1.35 oz.

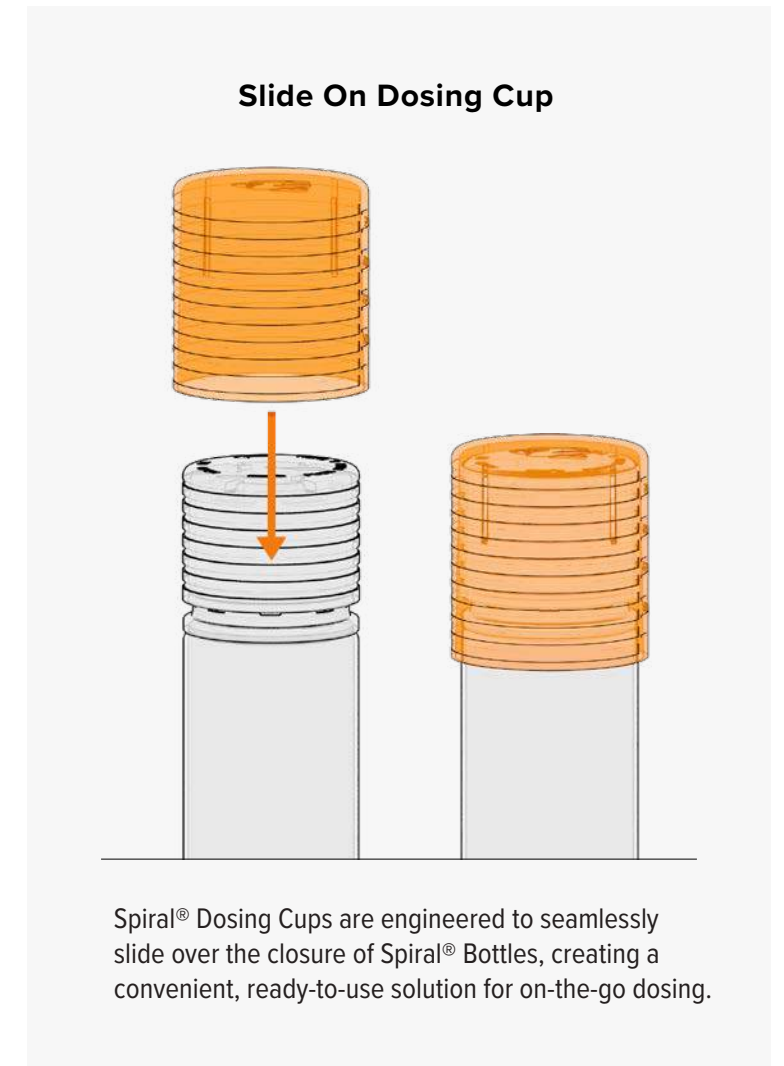

SPIRAL® DOSING CUPS

Available Sizes
9 mL | 20 mL | 40 mL

Spiral® Dosing Cups, paired with Spiral® Bottles, offer precise liquid measurements from 3 mL to 9 mL, 5 mL to 20 mL, and 5 mL to 40 mL. This versatile cup enables convenient dosing at home or on-the-go.

KEY FEATURES [LEARN MORE](#)

- Marked graduated dosing cups, ranging from 3 mL to 9 mL, 5 mL to 20 mL, and 5 mL to 40 mL. (Bottles sold separately)

- Slide On Dosing Cup
- Durable PP Dosing Cup



BK Clear Natural Bottle with Opaque Black Closure



BKBK Translucent Black Bottle with Opaque Black Closure
(excludes Unicorn Bottle® with Reducer)



WTC Clear Natural Bottle with Opaque White Closure



BK-SOLID Opaque Black Bottle with Opaque Black Closure



NATL Clear Natural Bottle with Clear Natural Closure



WT-SOLID Opaque White Bottle with Opaque White Closure

UNICORN BOTTLE®

| MODEL NO. | CAPACITY | NECK SIZE | CASE QTY. | INNER PACKING |
|---------------|-------------------|-----------|-----------|----------------|
| CGUB1-5MLV3 | 5 mL, 0.17 oz. | T15 | 2000 | 2 BAGS OF 1000 |
| CGUB1-9MLV3 | 9 mL, 0.30 oz. | T15 | 2000 | 2 BAGS OF 1000 |
| CGUB1-10MLV3 | 10 mL, 0.34 oz. | T15 | 2000 | 2 BAGS OF 1000 |
| CGUB1-15MLV3 | 16.5 mL, 0.56 oz. | T15 | 1000 | 10 BAGS OF 100 |
| CGUB1-20MLV3 | 20 mL, 0.68 oz. | T15 | 1000 | 10 BAGS OF 100 |
| CGUB1-20MLSC | 20 mL, 0.68 oz. | T24 | 1000 | 10 BAGS OF 100 |
| CGUB1-30MLV3 | 30 mL, 1.01 oz. | T15 | 1000 | 10 BAGS OF 100 |
| CGUB1-30MLSC | 30 mL, 1.01 oz. | T24 | 1000 | 10 BAGS OF 100 |
| CGUB1-50MLV3 | 50 mL, 1.69 oz. | T24 | 500 | 5 BAGS OF 100 |
| CGUB1-60MLV3 | 60 mL, 2.03 oz. | T24 | 500 | 5 BAGS OF 100 |
| CGUB1-60MLM | 60 mL, 2.03 oz. | T32 | 500 | 5 BAGS OF 100 |
| CGUB1-60MLSC | 60 mL, 2.03 oz. | T35 | 500 | 5 BAGS OF 100 |
| CGUB1-75MLV3 | 75 mL, 2.54 oz. | T24 | 500 | 5 BAGS OF 100 |
| CGUB1-75MLSC | 75 mL, 2.54 oz. | T35 | 500 | 5 BAGS OF 100 |
| CGUB1-75MLM | 75 mL, 2.54 oz. | T32 | 400 | 4 BAGS OF 100 |
| CGUB1-100MLV3 | 100 mL, 3.38 oz. | T35 | 400 | 4 BAGS OF 100 |
| CGUB1-120MLV3 | 120 mL, 4.06 oz. | T35 | 400 | 4 BAGS OF 100 |

UNICORN BOTTLE® WITH REDUCER

| MODEL NO. | CAPACITY | NECK SIZE | CASE QTY. | INNER PACKING |
|---------------|------------------|-----------|-----------|----------------|
| CGUB1-5MLR | 5 mL, 0.17 oz. | T15 | 2000 | 2 BAGS OF 1000 |
| CGUB1-9MLR | 9 mL, 0.30 oz. | T15 | 2000 | 2 BAGS OF 1000 |
| CGUB1-10MLR | 10 mL, 0.34 oz. | T15 | 2000 | 2 BAGS OF 1000 |
| CGUB1-15MLR | 15 mL, 0.51 oz. | T15 | 1000 | 10 BAGS OF 100 |
| CGUB1-20MLR | 20 mL, 0.68 oz. | T15 | 1000 | 10 BAGS OF 100 |
| CGUB1-30MLR | 30 mL, 1.01 oz. | T15 | 1000 | 10 BAGS OF 100 |
| CGUB1-30MLSCR | 30 mL, 1.01 oz. | T24 | 1000 | 10 BAGS OF 100 |
| CGUB1-50MLR | 50 mL, 1.69 oz. | T24 | 500 | 5 BAGS OF 100 |
| CGUB1-60MLR | 60 mL, 2.03 oz. | T24 | 500 | 5 BAGS OF 100 |
| CGUB1-100MLR | 100 mL, 3.38 oz. | T35 | 400 | 4 BAGS OF 100 |
| CGUB1-120MLR | 120 mL, 4.06 oz. | T35 | 400 | 4 BAGS OF 100 |



CNL-OBK Clear Natural Container with Opaque Black Closure



CNL-OWH Clear Natural Container with Opaque White Closure



CNL-CNL Clear Natural Container with Clear Natural Closure
(Spiral® Shot Bottles and Aviator® Shot Bottles only)



OBK-OBK Opaque Black Container with Opaque Black Closure



OWH-OWH Opaque White Container with Opaque White Closure

SPIRAL® SHOT BOTTLES

| MODEL NO. | CAPACITY | NECK SIZE | CASE QTY | INNER PACKING |
|---------------|------------------|-----------|----------|---------------|
| CGSSB1-30MLSC | 30 mL, 1.01 oz. | T28 | 800 | 8 BAGS OF 100 |
| CGSSB1-60MLM | 60 mL, 2.03 oz. | T28 | 500 | 5 BAGS OF 100 |
| CGSSB1-60ML | 60 mL, 2.03 oz. | T28 | 400 | 5 BAGS OF 100 |
| CGSSB1-100MLM | 100 mL, 3.38 oz. | T28 | 400 | 4 BAGS OF 100 |

SPIRAL® BOTTLES

| MODEL NO. | CAPACITY | NECK SIZE | CASE QTY | INNER PACKING |
|--------------|-------------------|-----------|----------|----------------|
| CGSB1-10ML | 10 mL, 0.34 oz. | T15 | 1000 | 10 BAGS OF 100 |
| CGSB1-16.5ML | 16.5 mL, 0.56 oz. | T15 | 1000 | 10 BAGS OF 100 |
| CGSB1-20ML | 20 mL, 0.68 oz. | T15 | 1000 | 10 BAGS OF 100 |
| CGSB1-30ML | 30 mL, 1.01 oz. | T15 | 1000 | 10 BAGS OF 100 |
| CGSB1-30MLSC | 30 mL, 1.01 oz. | T24 | 1000 | 10 BAGS OF 100 |
| CGSB1-50ML | 50 mL, 1.69 oz. | T24 | 500 | 5 BAGS OF 100 |
| CGSB1-60ML | 60 mL, 2.03 oz. | T24 | 500 | 5 BAGS OF 100 |
| CGSB1-100ML | 100 mL, 3.38 oz. | T35 | 400 | 4 BAGS OF 100 |
| CGSB1-120ML | 120 mL, 4.06 oz. | T35 | 400 | 4 BAGS OF 100 |

AVIATOR® SHOT BOTTLES

| MODEL NO. | CAPACITY | NECK SIZE | CASE QTY | INNER PACKING |
|---------------|------------------|-----------|----------|---------------|
| CGASB1-30MLSC | 30 mL, 1.01 oz. | T28 | 800 | 8 BAGS OF 100 |
| CGASB1-60ML | 60 mL, 2.03 oz. | T28 | 500 | 5 BAGS OF 100 |
| CGASB1-60MLM | 60 mL, 2.03 oz. | T28 | 500 | 5 BAGS OF 100 |
| CGASB1-100MLM | 100 mL, 3.38 oz. | T28 | 400 | 4 BAGS OF 100 |

AVIATOR® BOTTLES

| MODEL NO. | CAPACITY | NECK SIZE | CASE QTY | INNER PACKING |
|--------------|-------------------|-----------|----------|----------------|
| CGAB1-10ML | 10 mL, 0.34 oz. | T15 | 1000 | 10 BAGS OF 100 |
| CGAB1-16.5ML | 16.5 mL, 0.56 oz. | T15 | 1000 | 10 BAGS OF 100 |
| CGAB1-20ML | 20 mL, 0.68 oz. | T15 | 1000 | 10 BAGS OF 100 |
| CGAB1-30ML | 30 mL, 1.01 oz. | T15 | 1000 | 10 BAGS OF 100 |
| CGAB1-30MLSC | 30 mL, 1.01 oz. | T24 | 1000 | 10 BAGS OF 100 |
| CGAB1-50ML | 50 mL, 1.69 oz. | T24 | 500 | 5 BAGS OF 100 |
| CGAB1-60ML | 60 mL, 2.03 oz. | T24 | 500 | 5 BAGS OF 100 |
| CGAB1-100ML | 100 mL, 3.38 oz. | T35 | 400 | 4 BAGS OF 100 |
| CGAB1-120ML | 120 mL, 4.06 oz. | T35 | 400 | 4 BAGS OF 100 |

AVIATOR® BASE BOTTLES ONLY



OBK-OBK Opaque Black Container with Opaque Black Closure and Clear Natural Dosing Cup

AVIATOR® BASE BOTTLES ONLY



OWH-OWH Opaque White Container with Opaque White Closure and Clear Natural Dosing Cup

SPIRAL® DOSING CUPS ONLY

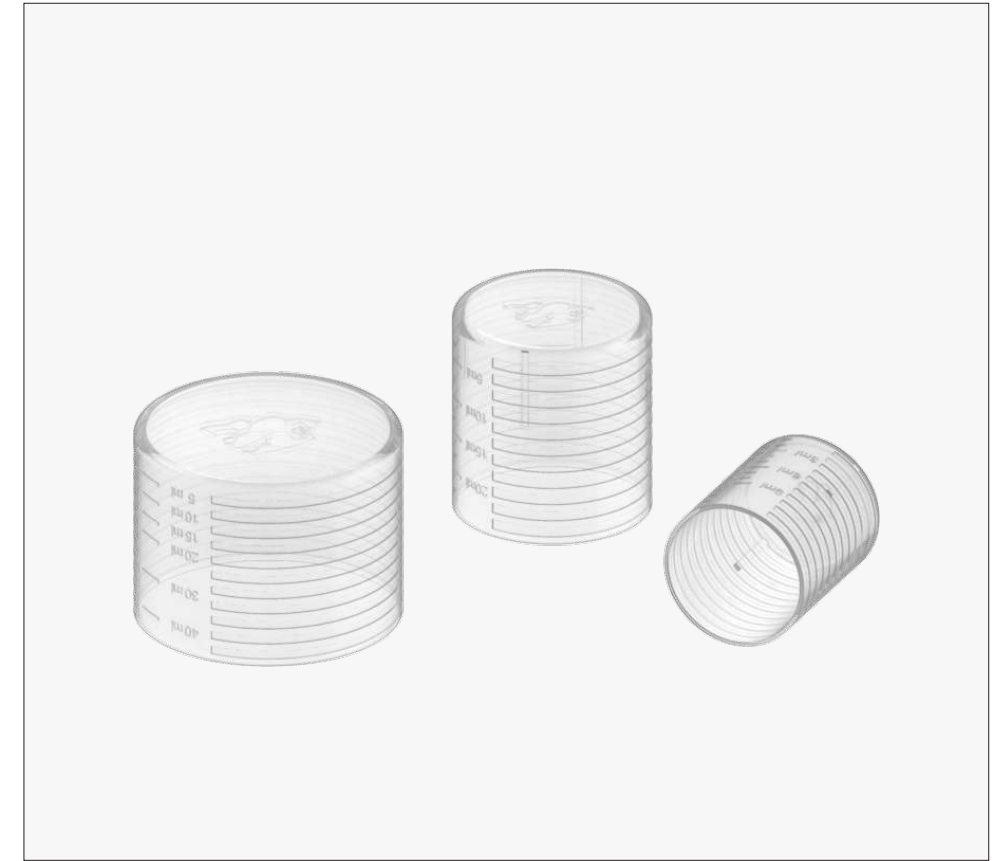

CNL Clear Natural Closure

AVIATOR® BASE BOTTLES

| MODEL NO. | CAPACITY | NECK SIZE | CASE QTY | INNER PACKING |
|--------------|---------------------------|-----------|----------|---------------|
| CGABB1-250ML | 250 mL, 8.45 oz., 250 cc | T48 | 120 | 4 BAGS OF 30 |
| CGABB1-500ML | 500 mL, 16.90 oz., 500 cc | T48 | 60 | 2 BAGS OF 30 |
| CGABB1-1LTR | 1 L, 33.81 oz., 1000 cc | T48 | 30 | 1 BAGS OF 30 |

SPIRAL® DOSING CUPS

| MODEL NO. | CAPACITY | CASE QTY | INNER PACKING |
|-------------------|-----------------|----------|----------------|
| CGSDCUP5-9ML-CNL | 9 mL, 0.30 oz. | 2000 | 20 BAGS OF 100 |
| CGSDCUP5-20ML-CNL | 20 mL, 0.68 oz. | 2000 | 20 BAGS OF 100 |
| CGSDCUP5-40ML-CNL | 40 mL, 1.35 oz. | 1000 | 10 BAGS OF 100 |



CONTAINERS

CONTAINERS WITH LINERS / THICK WALL /
WIDE MOUTH / DEVICE

Chubby Gorilla® provides a comprehensive range of containers designed specifically for solid goods and devices. Each container is engineered with purpose-built features, such as integrated liners, fastened tamper-evident bands, and child-resistant closures, to help deliver a reliable, consistent consumer experience. With this combination of dependable performance and distinctive aesthetics, Chubby Gorilla® helps brands stand out while ensuring the compliance their products deserve.



CONTAINERS WITH LINERS

CONTAINERS

SPIRAL® CONTAINERS
AVIATOR® CONTAINERS

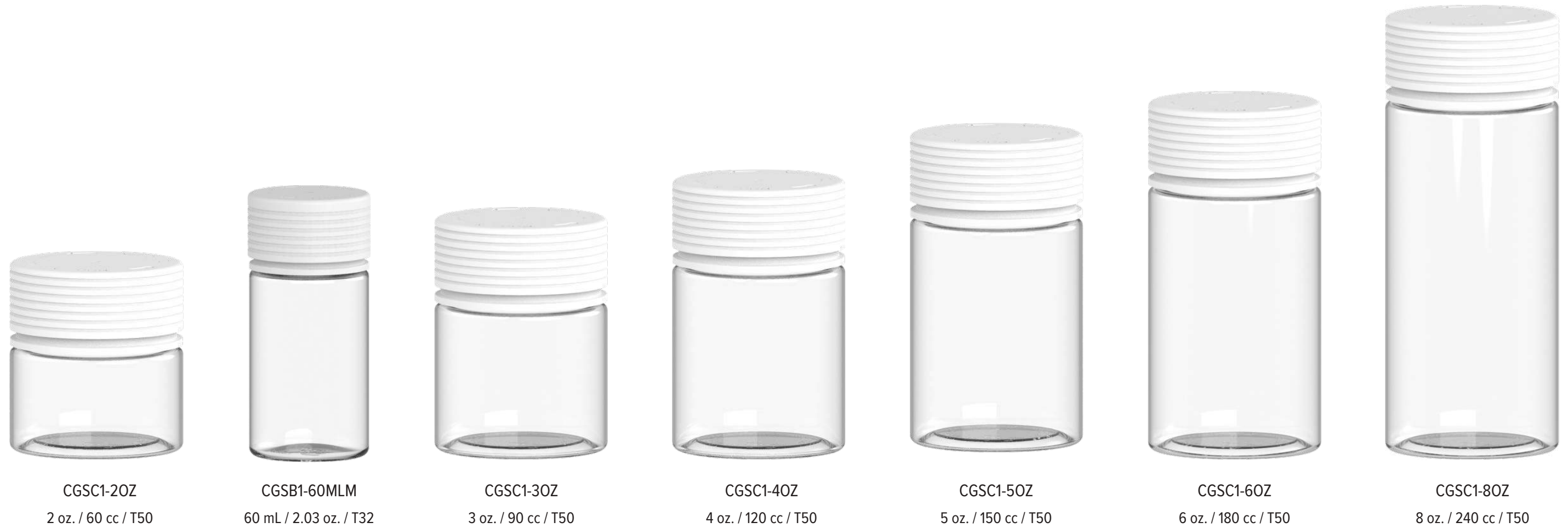

SPIRAL® CONTAINERS

Available Sizes
2 oz. | 60 mL MINI | 3 oz. | 4 oz. |
5 oz. | 6 oz. | 8 oz.

Elevate your packaging with the clean lines and modern aesthetics of Chubby Gorilla's Spiral® Containers. These Containers are a great solution for various products including powders, solid goods, supplements, and vitamins. All Spiral® Containers are purpose-built with key features focused to help support your brand while in a child-resistant closure system.

KEY FEATURES [LEARN MORE](#)

- All-In-One Smartcap
- Child-Resistant Closure
- Rotational Suspension Closure
- Fastened Tamper-Evident Band
- Integrated Liner
- Contoured Groove Surface
- Designed & Engineered In California USA
- Protected by Design Patent and/or Design Registration and Additional Patents Pending
- Embossed with Proprietary, Signature Gorilla Logo as a Stamp of Absolute Quality and Authenticity



CGAB1-60MLM
60 mL / 2.03 oz. / T32

CGAC1-2OZ
2 oz. / 60 cc / T50

CGAC1-3OZ
3 oz. / 90 cc / T50

CGAC1-4OZ
4 oz. / 120 cc / T50

CGAC1-5OZ
5 oz. / 150 cc / T50

CGAC1-6OZ
6 oz. / 180 cc / T50

CGAC1-8OZ
8 oz. / 240 cc / T50

AVIATOR® CONTAINERS

Available Sizes
2 oz. | 60 mL MINI | 3 oz. | 4 oz. | 5 oz. |
6 oz. | 8 oz.

Available in a multitude of sizes, our Aviator® Containers can be used to store and dispense plant-wellness products, supplements, and vitamins. All Aviator® Containers are purpose-built with key features focused to help support your brand while in a child-resistant closure system.

KEY FEATURES [LEARN MORE](#)

- All-In-One Smartcap
- Child-Resistant Closure
- HoverGLIDE Rotational Suspension Closure
- Fastened Tamper-Evident Band
- Integrated Liner
- 360 Micro-Grip Diamond Surface
- Designed & Engineered In California USA
- Protected by Design Patent and/or Design Registration and Additional Patents Pending
- Embossed with Proprietary, Signature Gorilla Logo as a Stamp of Absolute Quality and Authenticity



THICK WALL CONTAINERS

SPIRAL® THICK WALL CONTAINERS



CGSC1-30MLMTW
1 oz. / 30 cc / T32



CGSC1-2OZTW
2 oz. / 60 cc / T50



SPIRAL® THICK WALL CONTAINERS

Available Sizes
1 oz. | 2 oz.

Spiral® Containers have long been a staple in the vitamin and supplement market, and now Chubby Gorilla® has elevated the standard with its thick-walled Spiral® Containers. These containers offer the premium look and appeal of glass, without the added weight or fragility. Ideal for brands aiming to enhance their image, Spiral® Thick Wall Containers deliver a sleek, durable packaging solution.

KEY FEATURES [LEARN MORE](#)

- All-In-One Smartcap
- Child-Resistant Closure
- Rotational Suspension Closure
- Fastened Tamper-Evident Band
- Integrated Liner
- Contoured Groove Surface
- Designed & Engineered In California USA
- Protected by Design Patent and/or Design Registration and Additional Patents Pending
- Embossed with Proprietary, Signature Gorilla Logo as a Stamp of Absolute Quality and Authenticity



WIDE MOUTH CONTAINERS

- SPIRAL® WIDE MOUTH CONTAINER
- SPIRAL® XL CONTAINERS
- AVIATOR® XL CONTAINERS



CGSC1-100ZWM
10 oz. / 300 cc / T53

SPIRAL® WIDE MOUTH CONTAINER

Available Size
10 oz.

The Spiral® Wide Mouth Container delivers the same generous storage capacity as our XL Containers, but in a more retail-friendly form factor. Its streamlined design enhances shelf presence while maintaining the durability brands rely on Chubby Gorilla® for.

KEY FEATURES [LEARN MORE](#)

- All-In-One Smartcap
- Child-Resistant Closure
- Rotational Suspension Closure
- Fastened Tamper-Evident Band
- Integrated Liner
- Contoured Groove Surface
- Designed & Engineered In California USA
- Protected by Design Patent and/or Design Registration and Additional Patents Pending
- Embossed with Proprietary, Signature Gorilla Logo as a Stamp of Absolute Quality and Authenticity



CGSC1-7.5OZXL
7.5 oz. / 220 cc / T83



CGSC1-10OZXL
10 oz. / 300 cc / T83



CGSC1-18.5OZXL
18.5 oz. / 550 cc / T83



CGSC1-21.5OZXL
21.5 oz. / 625 cc / T83

SPIRAL® XL CONTAINERS

Available Sizes
7.5 oz. | 10 oz. | 18.5 oz. | 21.5 oz.

Engineered to hold a variety of volumes with small and large contents. Our Spiral® XL Containers are the perfect packaging solutions for your large-scale needs. Ready to make an impact on your brand, Spiral® XL Containers masterfully integrate smart features for high volume packaging requirements.

KEY FEATURES [LEARN MORE](#)

- All-In-One Smartcap
- Child-Resistant Closure
- Rotational Suspension Closure
- Fastened Tamper-Evident Band
- Integrated Liner
- Contoured Groove Surface
- Designed & Engineered In California USA
- Protected by Design Patent and/or Design Registration and Additional Patents Pending
- Embossed with Proprietary, Signature Gorilla Logo as a Stamp of Absolute Quality and Authenticity



CGAC1-7.5OZXL
7.5 oz. / 220 cc / T83



CGAC1-10OZXL
10 oz. / 300 cc / T83



CGAC1-18.5OZXL
18.5 oz. / 550 cc / T83



CGAC1-21.5OZXL
21.5 oz. / 625 cc / T83

AVIATOR® XL CONTAINERS

Available Sizes
7.5 oz. | 10 oz. | 18.5 oz. | 21.5 oz.

Aviator® XL Containers bring large format storage for plant-wellness products, supplements, and vitamins. The line of Aviator® XL Containers feature an integrated liner in the closure to help support loud odors from escaping the container. All Aviator® XL Containers are purpose-built with key features focused to help support your brand while in a child-resistant closure system.

KEY FEATURES [LEARN MORE](#)

- All-In-One Smartcap
- Child-Resistant Closure
- HoverGLIDE Rotational Suspension Closure
- Fastened Tamper-Evident Band
- Integrated Liner
- 360 Micro-Grip Diamond Surface
- Designed & Engineered In California USA
- Protected by Design Patent and/or Design Registration and Additional Patents Pending
- Embossed with Proprietary, Signature Gorilla Logo as a Stamp of Absolute Quality and Authenticity



DEVICE CONTAINERS

SPIRAL® 510-CARTRIDGE CONTAINERS
AVIATOR® 510-CARTRIDGE CONTAINERS



CGSC1-510F
65 mm / T22

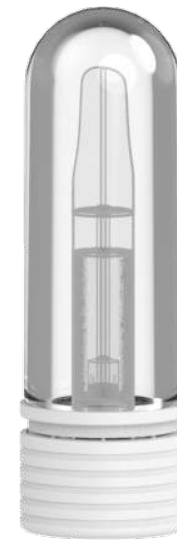

CGSC1-510R
65 mm / T22

Universal 510-Thread Holder



The 510-Thread holder is integrated into the closure to hold cartridges in place in a variety of orientations.

SPIRAL® 510-CARTRIDGE CONTAINERS

Available Formats
65 mm Flat | 65 mm Round

Chubby Gorilla® Spiral® 510-Cartridge Containers have set the new bar for cartridge packaging. The Spiral® 510-Cartridge Container has the capacity to hold 65mm in length cartridges in a compact and contemporary styled packaging solution.
**510-Cartridge not included*

KEY FEATURES [LEARN MORE](#)

- All-In-One Smartcap
- Child-Resistant Closure
- Rotational Suspension Closure
- Fastened Tamper-Evident Band
- Universal 510 Thread Holder
- Contoured Groove Surface
- Heavy Duty Container Construction
- Designed & Engineered In California USA
- Protected by Design Patent and/or Design Registration and Additional Patents Pending



CGAC1-510F
65mm / T18



CGAC1-510R
65mm / T18

Universal 510-Thread Holder



The 510-Thread holder is integrated into the closure to hold cartridges in place in a variety of orientations.

AVIATOR® 510-CARTRIDGE CONTAINERS

Available Formats
65 mm FLAT | 65 mm Round

Chubby Gorilla® Aviator® 510-Cartridge Containers have set the new bar for cartridge packaging. The Aviator® 510-Cartridge Container has the capacity to hold 65mm in length cartridges in a compact and contemporary styled packaging solution.
**510-Cartridge not included*

KEY FEATURES [LEARN MORE](#)

- All-In-One Smartcap
- Child-Resistant Closure
- Rotational Suspension Closure
- Universal 510-Thread Holder
- Fastened Tamper-Evident Band
- 360 Micro-Grip Diamond Surface
- Heavy Duty Container Construction
- Protected by Design Patent and/or Design Registration and Additional Patents Pending
- Designed & Engineered In California, USA



CNL-OBK
Clear Natural Container
with Opaque Black Closure



CNL-OWH
Clear Natural Container
with Opaque White Closure



OBK-OBK
Opaque Black Container
with Opaque Black Closure



OWH-OWH
Opaque White Container
with Opaque White Closure

SPIRAL® CONTAINERS

| MODEL NO. | CAPACITY | NECK SIZE | CASE QTY | INNER PACKING |
|-------------|-----------------|-----------|----------|---------------|
| CGSC1-2OZ | 2 oz., 60 cc | T50 | 400 | 4 BAGS OF 100 |
| CGSB1-60MLM | 60 mL, 2.03 oz. | T32 | 500 | 5 BAGS OF 100 |
| CGSC1-3OZ | 3 oz., 90 cc | T50 | 400 | 4 BAGS OF 100 |
| CGSC1-4OZ | 4 oz., 120 cc | T50 | 400 | 4 BAGS OF 100 |
| CGSC1-5OZ | 5 oz., 150 cc | T50 | 300 | 3 BAGS OF 100 |
| CGSC1-6OZ | 6 oz., 180 cc | T50 | 300 | 3 BAGS OF 100 |
| CGSC1-8OZ | 8 oz., 240 cc | T50 | 200 | 2 BAGS OF 100 |

SPIRAL® THICK WALL CONTAINERS

| MODEL NO. | CAPACITY | NECK SIZE | CASE QTY | INNER PACKING |
|---------------|--------------|-----------|----------|---------------|
| CGSC1-30MLMTW | 30 mL, 1 oz. | T32 | 200 | 2 BAGS OF 100 |
| CGSC1-2OZTW | 2 oz., 60 cc | T50 | 150 | 3 BAGS OF 50 |

SPIRAL® XL CONTAINERS

| MODEL NO. | CAPACITY | NECK SIZE | CASE QTY | INNER PACKING |
|----------------|------------------|-----------|----------|---------------|
| CGSC1-7.5OZXL | 7.5 oz., 220 cc | T83 | 100 | 5 BAGS OF 20 |
| CGSC1-10OZXL | 10 oz., 300 cc | T83 | 80 | 4 BAGS OF 20 |
| CGSC1-18.5OZXL | 18.5 oz., 550 cc | T83 | 60 | 3 BAGS OF 20 |
| CGSC1-21.5OZXL | 21.5 oz., 625 cc | T83 | 40 | 2 BAGS OF 20 |

SPIRAL® 510-CARTRIDGE CONTAINERS

| MODEL NO. | CAPACITY | NECK SIZE | CASE QTY | INNER PACKING |
|------------|----------|-----------|----------|---------------|
| CGSC1-510R | 65 mm | T22 | 400 | 4 BAGS OF 100 |
| CGSC1-510F | 65 mm | T22 | 400 | 4 BAGS OF 100 |

AVIATOR® CONTAINERS

| MODEL NO. | CAPACITY | NECK SIZE | CASE QTY | INNER PACKING |
|-------------|-----------------|-----------|----------|---------------|
| CGAC1-2OZ | 2 oz., 60 cc | T50 | 500 | 5 BAGS OF 100 |
| CGAB1-60MLM | 60 mL, 2.03 oz. | T32 | 500 | 5 BAGS OF 100 |
| CGAC1-3OZ | 3 oz., 90 cc | T50 | 400 | 4 BAGS OF 100 |
| CGAC1-4OZ | 4 oz., 120 cc | T50 | 400 | 4 BAGS OF 100 |
| CGAC1-5OZ | 5 oz., 150 cc | T50 | 300 | 3 BAGS OF 100 |
| CGAC1-6OZ | 6 oz., 180 cc | T50 | 300 | 3 BAGS OF 100 |
| CGAC1-8OZ | 8 oz., 240 cc | T50 | 200 | 2 BAGS OF 100 |

SPIRAL® WIDE MOUTH CONTAINER

| MODEL NO. | CAPACITY | NECK SIZE | CASE QTY | INNER PACKING |
|--------------|----------------|-----------|----------|---------------|
| CGSC1-10OZWM | 10 oz., 300 cc | T53 | 120 | 2 BAGS OF 60 |

AVIATOR® XL CONTAINERS

| MODEL NO. | CAPACITY | NECK SIZE | CASE QTY | INNER PACKING |
|----------------|------------------|-----------|----------|---------------|
| CGAC1-7.5OZXL | 7.5 oz., 220 cc | T83 | 100 | 5 BAGS OF 20 |
| CGAC1-10OZXL | 10 oz., 300 cc | T83 | 80 | 4 BAGS OF 20 |
| CGAC1-18.5OZXL | 18.5 oz., 550 cc | T83 | 60 | 3 BAGS OF 20 |
| CGAC1-21.5OZXL | 21.5 oz., 625 cc | T83 | 40 | 2 BAGS OF 20 |

AVIATOR® 510-CARTRIDGE CONTAINERS

| MODEL NO. | CAPACITY | NECK SIZE | CASE QTY | INNER PACKING |
|------------|----------|-----------|----------|---------------|
| CGAC1-510R | 65 mm | T18 | 500 | 5 BAGS OF 100 |
| CGAC1-510F | 65 mm | T18 | 500 | 5 BAGS OF 100 |



POUCH CONTAINERS

**SINGLE COMPARTMENT / DUAL COMPARTMENT /
HIGH CAPACITY**

Chubby Gorilla's new Pouch Container line introduces a versatile range of packaging solutions designed for the fast-growing pouch market, as well as for Nootropics and Supplements. Available in 40 g, 50 g, 80 g, and 100 g capacities all backed by the trusted engineering excellence that defines Chubby Gorilla®.



SINGLE COMPARTMENT

POUCH CONTAINERS

X3 SINGLE COMPARTMENT



CGPC5-50GL
50 g

Push Down and Turn 3-Way Child-Resistant Closure

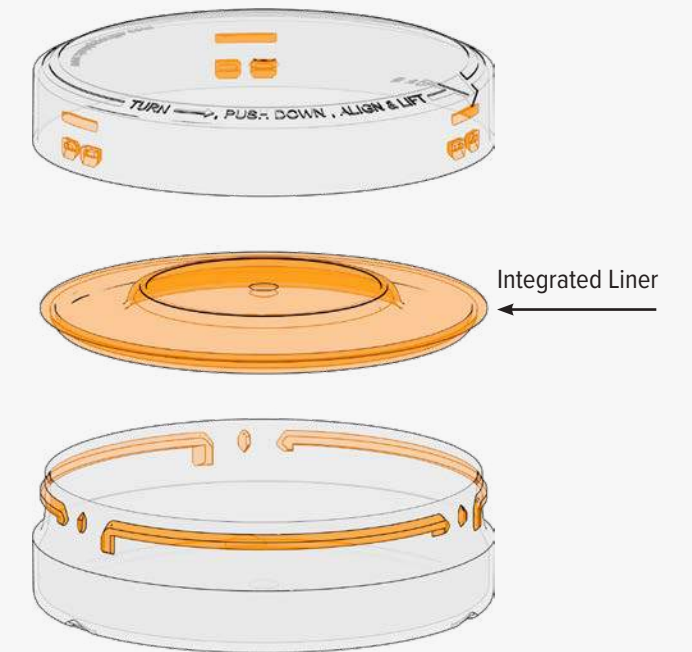

The 3-Way CR Container Closure System is designed for easy opening, featuring three clearly marked positions at the bottom of container that helps to guide users through the process.

X3 SINGLE COMPARTMENT POUCH CONTAINER

Available Size
50 g

Discover the X3 50 g Pouch Container from Chubby Gorilla®, where classic convenience meets next-generation innovation. Featuring our patented 3-Way Child-Resistant Closure System and an Integrated Liner, the X3 delivers an elevated experience in one sleek design. Purpose-built to integrate seamlessly into existing production lines, it offers unmatched efficiency, premium quality, and lasting value.

KEY FEATURES [LEARN MORE](#)

- Integrated Liner
- Single Storage Compartment
- Three-Way Child-Resistant Closure System
- Designed & Engineered In California, USA



DUAL COMPARTMENT POUCH CONTAINERS

| X2 DUAL COMPARTMENT



CGPC5-40G
40 g

Dual Storage Compartments



The integrated dual storage compartments are engineered to dispense pouches and store disposed pouches in a compact container.

X2 DUAL COMPARTMENT POUCH CONTAINER

Available Size
40 g

Chubby Gorilla® redefined the pouch container category with the launch of the world's first Dual Compartment X2 Pouch Container featuring a child-resistant upper closure. Engineered for everyday convenience, the X2 offers a smart way to separate fresh and used pouches in the 40 g container with a dedicated disposal compartment.

KEY FEATURES [LEARN MORE](#)

- Child-Resistant Upper Closure
- Dual Storage Compartments
- 360 Micro-Grip Diamond Surface
- Designed & Engineered In California, USA



HIGH CAPACITY POUCH CONTAINERS

X1 HIGH CAPACITY



CGPC5-80G
80 g



CGPC5-100G
100 g



X1 HIGH-CAPACITY POUCH CONTAINERS

Available Sizes
80 g | 100 g

Chubby Gorilla's High-Capacity X1 Pouch Containers prove that more is truly better. With a patented child-resistant upper closure and generous storage options in 80 g and 100 g formats, the X1 series is designed to deliver maximum value and shelf impact. Built for brands that want to stand out, the X1 combines scale and standout design in every container.

KEY FEATURES [LEARN MORE](#)

- Child-Resistant Closure System (Pending)
- 360 Micro-Grip Diamond Surface
- High Capacity Storage Compartment
- Designed & Engineered In California, USA



CNL-OBK
Clear Natural Container with Opaque Black Closures (Gloss)



CNL-OWH
Clear Natural Container with Opaque White Closures (Gloss)



CNL-CNL
Clear Natural Container with Clear Natural Closures (Gloss)



OBK-OBK
Opaque Black Container with Opaque Black Closures (Gloss)



OWH-OWH
Opaque White Container with Opaque White Closures (Gloss)

X3 SINGLE COMPARTMENT POUCH CONTAINER

| MODEL NO. | CAPACITY | NECK SIZE | CASE QTY. | INNER PACKING |
|------------|----------|-----------|-----------|---------------|
| CGPC5-50GL | 50 g | T66 | 500 | 5 BAGS OF 100 |

X2 DUAL COMPARTMENT POUCH CONTAINER

| MODEL NO. | CAPACITY | NECK SIZE | CASE QTY. | INNER PACKING |
|-----------|----------|-----------|-----------|---------------|
| CGPC5-40G | 40 g | T66 | 600 | 6 BAGS OF 100 |

X1 HIGH CAPACITY POUCH CONTAINER

| MODEL NO. | CAPACITY | NECK SIZE | CASE QTY. | INNER PACKING |
|------------|----------|-----------|-----------|---------------|
| CGPC5-80G | 80 g | T66 | 480 | 8 BAGS OF 60 |
| CGPC5-100G | 100 g | T66 | 300 | 5 BAGS OF 60 |

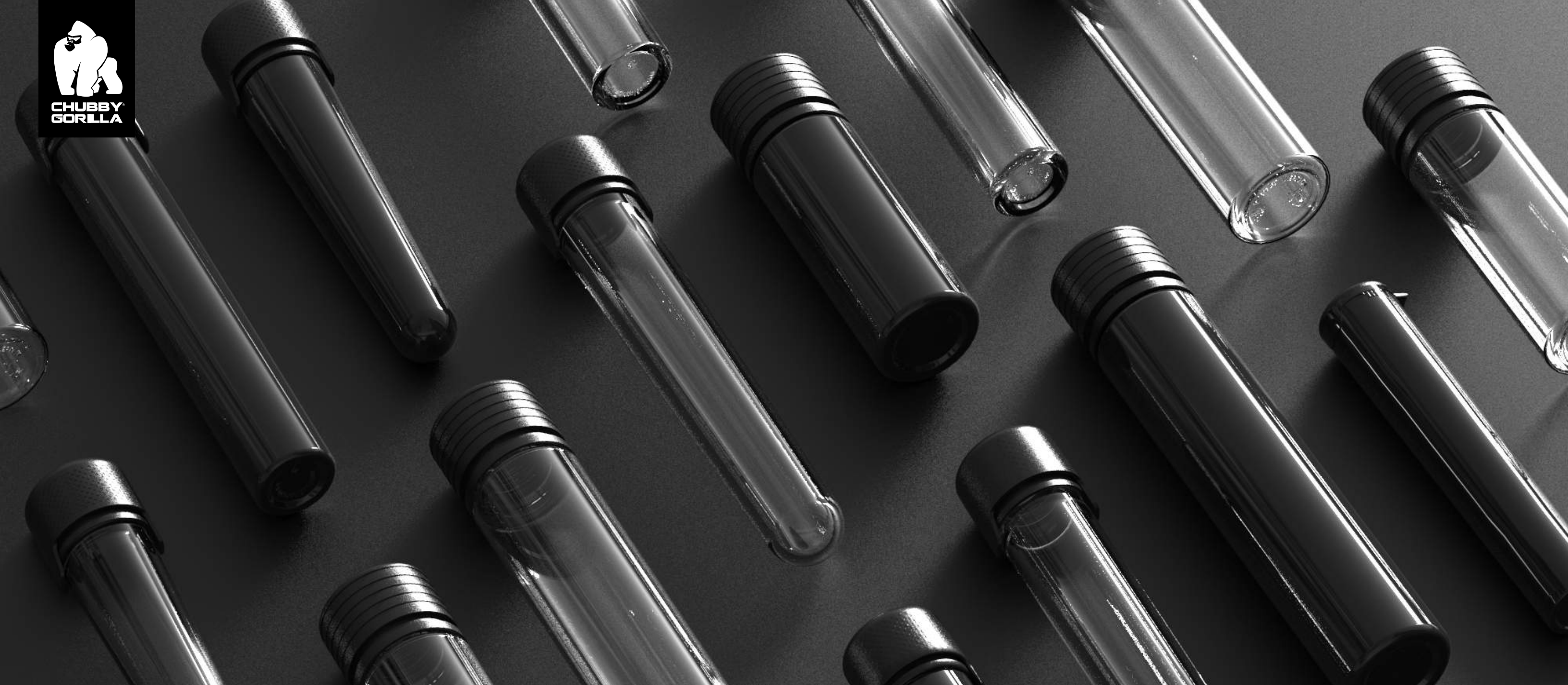

TUBES

STRAIGHT / TAPERED / POPCAP

Chubby Gorilla® Tubes have been creatively adopted across an incredible range of industries. Available in both tapered and straight-wall designs, these visually striking tubes feature integrated liners and child-resistant closures. Their rugged, highly durable construction makes them an ideal packaging solution, delivering both strong retail appeal and dependable performance.



STRAIGHT TUBES

SPIRAL[®] TUBES
AVIATOR[®] TUBES



CGST1-65MM
0.44 oz. / 13 mL / T22



CGST1-95MM
0.64 oz. / 19 mL / T22



CGST1-115MM
0.78 oz. / 23 mL / T22

SPIRAL® TUBES

Available Sizes
65 mm | 95 mm | 115 mm

Featuring clean-lines & contemporary aesthetics, the Spiral® Tubes offer solutions for a variety of products. These tubes have the look and feel of glass with a lighter and elegant weight. Spiral® Tubes are specially engineered to offer a refined solution for a variety of products, helping to set your brand apart from the others.

KEY FEATURES [LEARN MORE](#)

- All-In-One Smartcap
- Child-Resistant Closure
- Rotational Suspension Closure
- Fastened Tamper-Evident Band
- Integrated Liner
- Contoured Groove Surface
- Heavy Duty Container Construction
- Designed & Engineered In California USA
- Protected by Design Patent and/or Design Registration and Additional Patents Pending



CGAT1-65MMF
10.5 mL / 0.36 oz / T18



CGAT1-100MMF
16.7 mL / 0.56 oz. / T18



CGAT1-115MMF
18.5 mL / 0.63 oz / T18

AVIATOR® TUBES

Available Sizes
65 mm FLAT | 100 mm FLAT | 115 mm FLAT

Sleek, stylish, and discreet, Aviator® Tubes are engineered for a variety of products. Aviator® Tubes feature a child-resistant closure, integrated liner, and a fastened tamper-evident band to greatly simplify the packaging process.

KEY FEATURES [LEARN MORE](#)

- All-In-One Smartcap
- Child-Resistant Closure
- Rotational Suspension Closure
- Fastened Tamper-Evident Band
- Integrated Liner
- 360 Micro-Grip Diamond Surface
- Heavy Duty Container Construction
- Designed & Engineered In California USA
- Protected by Design Patent and/or Design Registration and Additional Patents Pending

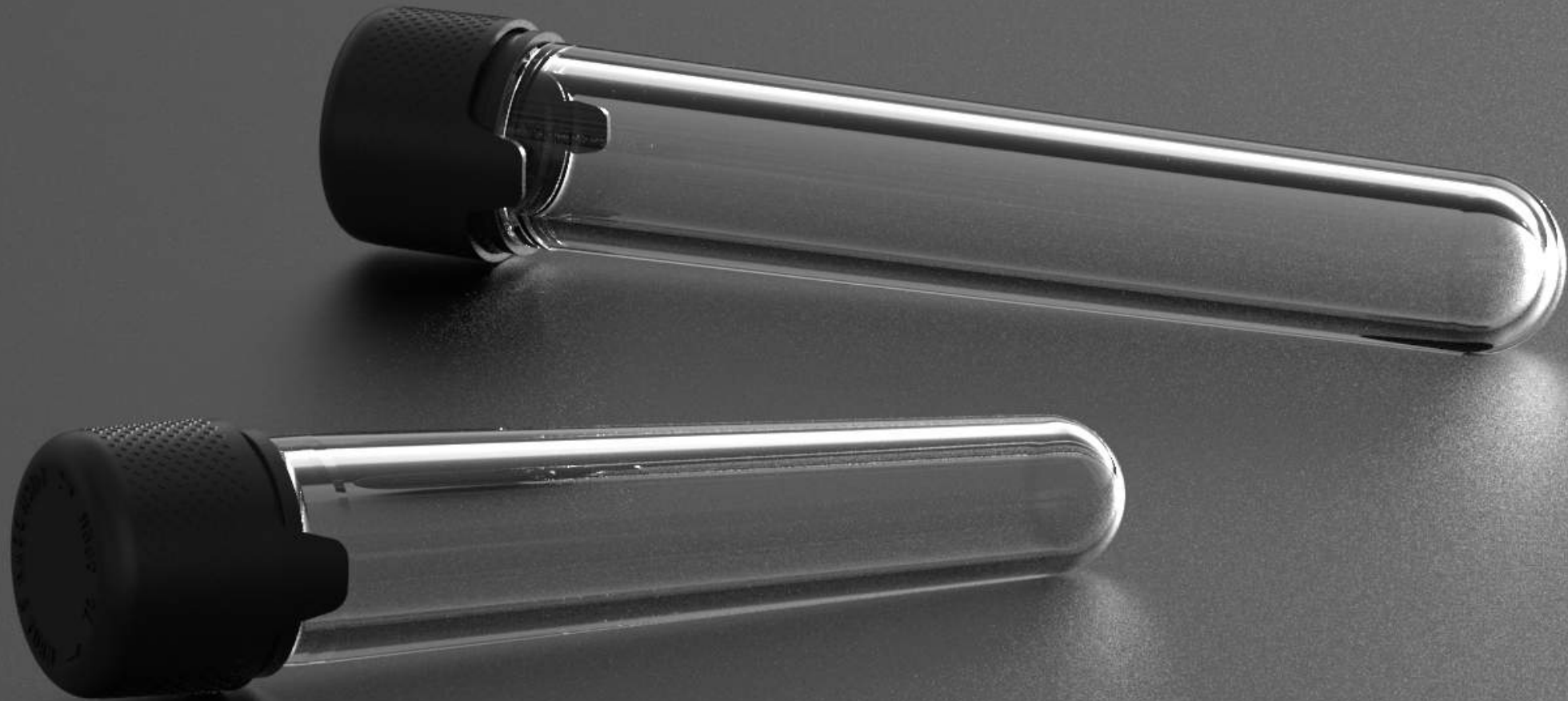

TAPERED TUBES

AVIATOR[®] TUBES



CGAT6-100MM
13 mL / 0.44 oz. / T18



CGAT6-120MM
18 mL / 0.61 oz. / T18

AVIATOR® TUBES

Available Sizes
100 mm | 120 mm

Sleek, stylish, and discreet, Aviator® Tubes are engineered for a variety of products. Aviator® Tubes feature a child-resistant closure, integrated liner, and a fastened tamper-evident band to greatly simplify the packaging process.

KEY FEATURES [LEARN MORE](#)

- All-In-One Smartcap
- Child-Resistant Closure
- Rotational Suspension Closure
- Fastened Tamper-Evident Band
- Integrated Liner
- 360 Micro-Grip Diamond Surface
- Heavy Duty Container Construction
- Designed & Engineered In California USA
- Protected by Design Patent and/or Design Registration and Additional Patents Pending



POPCAP TUBES

| AVIATOR® POPCAP TUBES



CGAPT5-78MM
13.5 mL



CGAPT5-98MM
18.5 mL



CGAPT5-116MM
21.5 mL

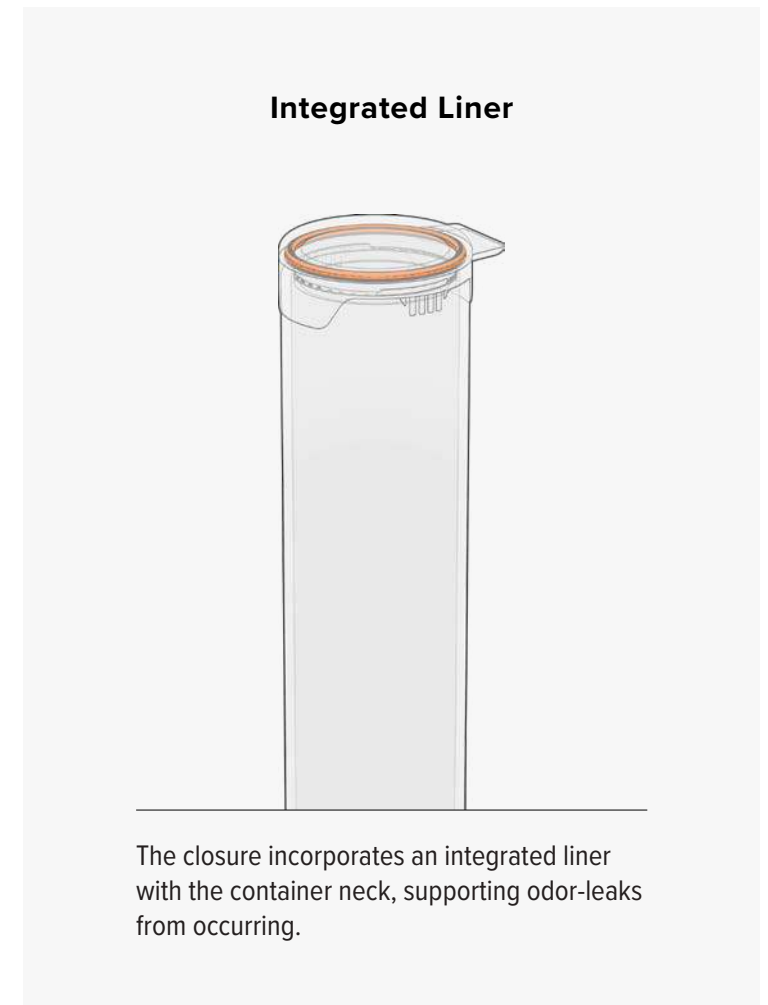

AVIATOR® POPCAP TUBES

Available Sizes
78 mm | 98 mm | 116 mm

Aviator® Pop Cap Tubes are designed to revolutionize the standard pop-top tube market. With sleek, slender lines, they deliver a modern and refreshed look that enhances any brand's presence. Available in three sizes, Chubby Gorilla's Aviator® Pop Cap Tubes are crafted to stand out and make a lasting impression on retail shelves.

KEY FEATURES [LEARN MORE](#)

- Integrated liner
- Designed & Engineered In California USA



CNL-OBK
Clear Natural Container with Opaque Black Closure
(excludes Aviator® PopCap Tubes)



CNL-OWH
Clear Natural Container with Opaque White Closure
(excludes Aviator® PopCap Tubes)



OBK-OBK
Opaque Black Container with Opaque Black Closure



OWH-OWH
Opaque White Container with Opaque White Closure

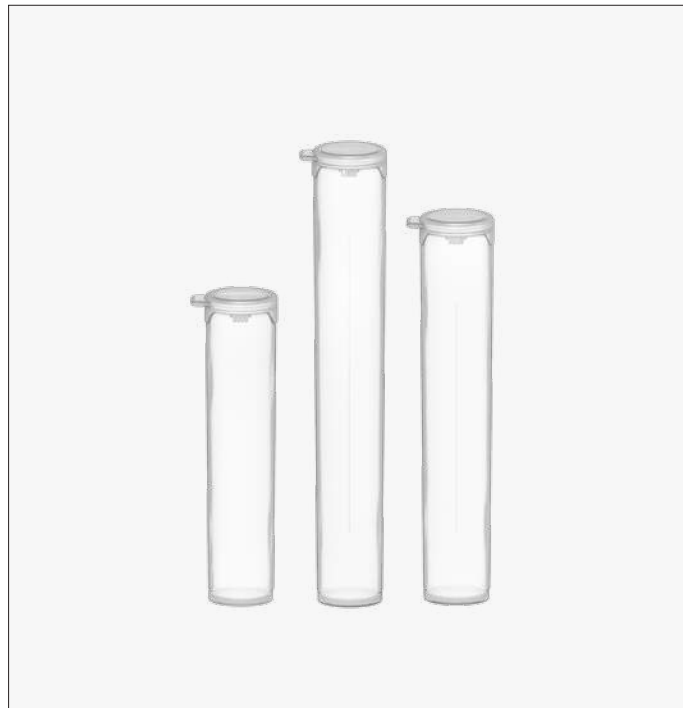

CNL-CNL
Clear Natural Container with Opaque Black Closure
(Aviator® PopCap Tubes only)

SPIRAL® TUBES

| MODEL NO. | CAPACITY | NECK SIZE | CASE QTY | INNER PACKING |
|-------------|-----------------------|-----------|----------|---------------|
| CGST1-65MM | 0.44 oz., 13 mL, 13 g | T22 | 400 | 4 BAGS OF 100 |
| CGST1-95MM | 0.64 oz., 19 mL, 19 g | T22 | 300 | 3 BAGS OF 100 |
| CGST1-115MM | 0.78 oz., 23 mL, 23 g | T22 | 200 | 2 BAGS OF 100 |

AVIATOR® TUBES (TAPERED)

| MODEL NO. | CAPACITY | NECK SIZE | CASE QTY | INNER PACKING |
|-------------|-----------------------|-----------|----------|---------------|
| CGAT6-100MM | 13 mL, 0.44 oz., 13 g | T18 | 500 | 5 BAGS OF 100 |
| CGAT6-120MM | 18 mL, 0.61 oz., 18 g | T18 | 500 | 5 BAGS OF 100 |

AVIATOR® TUBES (STRAIGHT)

| MODEL NO. | CAPACITY | NECK SIZE | CASE QTY | INNER PACKING |
|--------------|---------------------------|-----------|----------|---------------|
| CGAT1-65MMF | 10.5 mL, 0.36 oz., 10.5 g | T18 | 500 | 5 BAGS OF 100 |
| CGAT1-100MMF | 16.7 mL, 0.56 oz., 16.7 g | T18 | 500 | 5 BAGS OF 100 |
| CGAT1-115MMF | 18.5 mL, 0.63 oz., 18.5 g | T18 | 400 | 4 BAGS OF 100 |

AVIATOR® POPCAP TUBES

| MODEL NO. | CAPACITY | NECK SIZE | CASE QTY | INNER PACKING |
|--------------|---------------------------|-----------|----------|---------------|
| CGAPT5-78MM | 14 mL, 0.47 oz., 14 g | N/A | 1500 | 3 BAGS OF 500 |
| CGAPT5-98MM | 17.5 mL, 0.59 oz., 17.5 g | N/A | 1500 | 3 BAGS OF 500 |
| CGAPT5-116MM | 20.5 mL, 0.69 oz., 20.5 g | N/A | 1500 | 3 BAGS OF 500 |

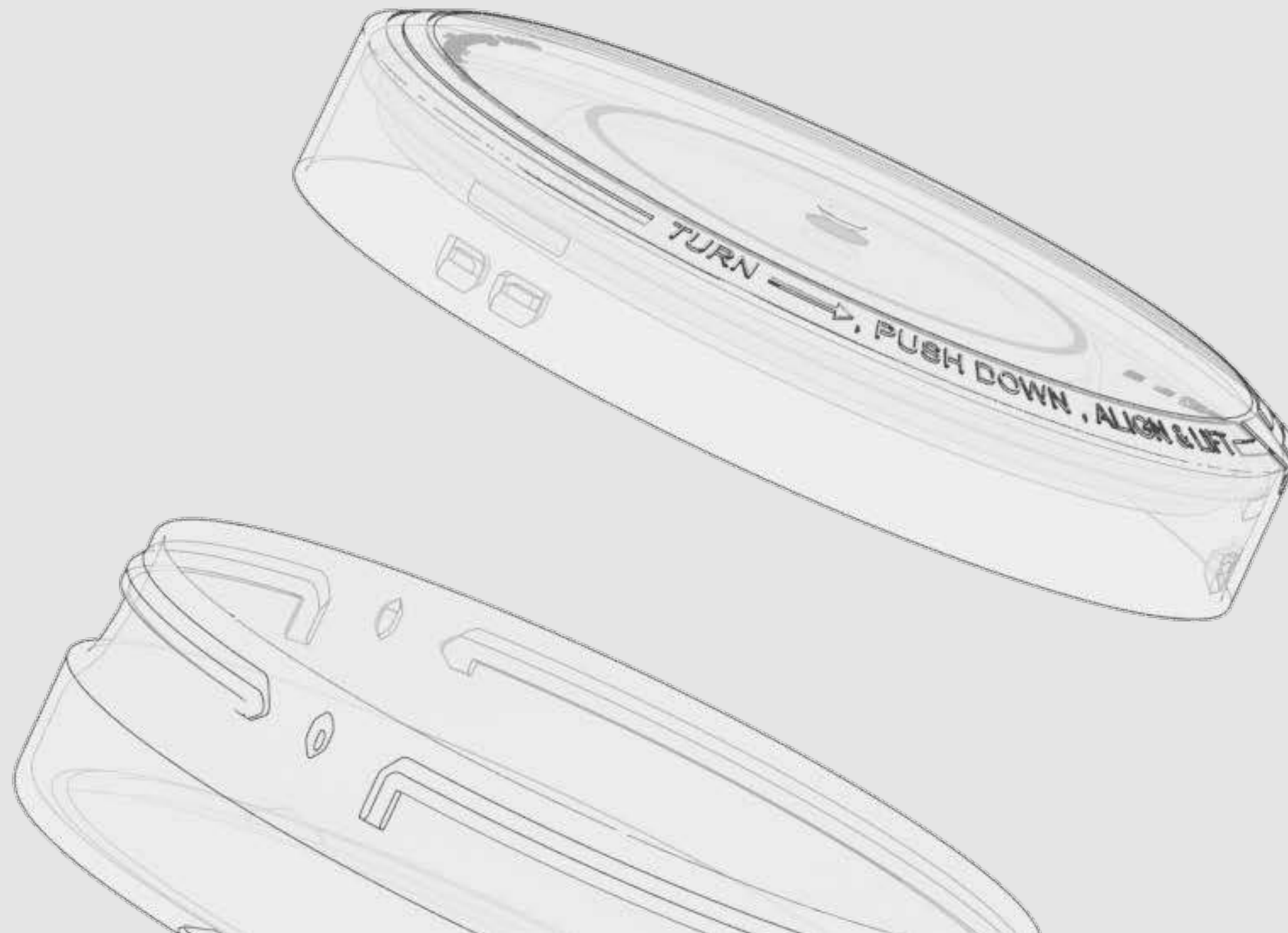

KEY FEATURES

GLOSSARY

At their core, all Chubby Gorilla® packaging solutions are defined by the purposeful features built into them. Each feature is intentionally engineered to meet the diverse needs of brands across a wide range of industries.

All-In-One SmartCap

The SmartCap simultaneously applies the tamper-evident band while closing the bottle/container/tube.

BOTTLES

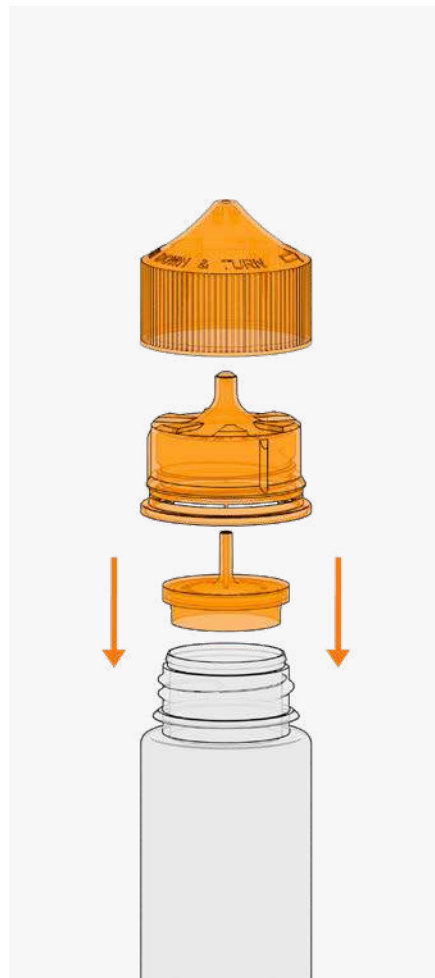

Dispensing / Beverage / Measurement

CONTAINERS

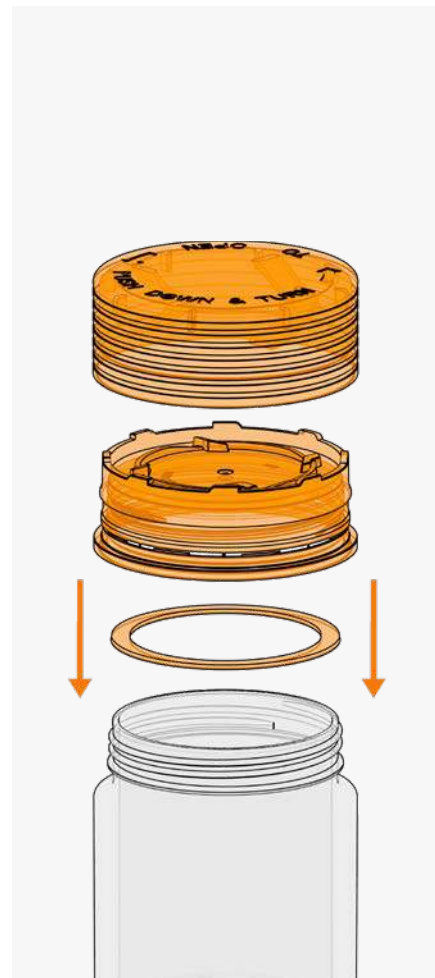

Containers with Liners / Thick Wall / Wide Mouth / Device

TUBES

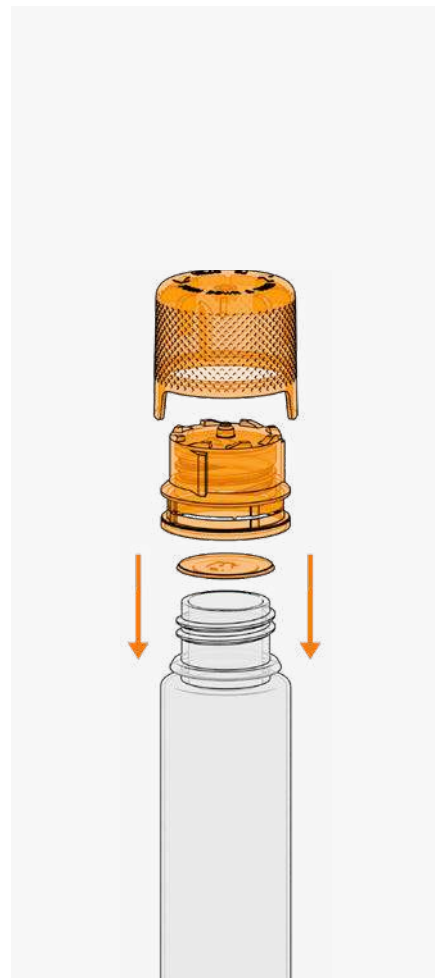

Straight / Tapered

**Click on product names to jump back to their pages*

Fastened Tamper-Evident Band

A smooth tamper-evident band remains latched onto the neck of the container.

BOTTLES

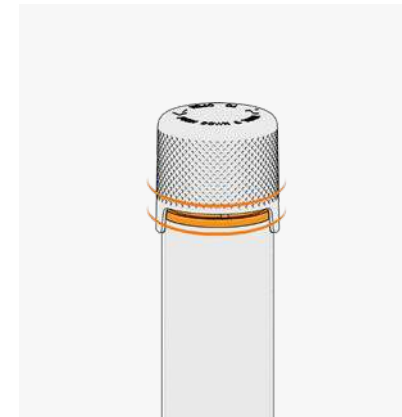

Dispensing / Beverage / Measurement

CONTAINERS



Containers with Liners / Thick Wall / Wide Mouth / Devices

TUBES

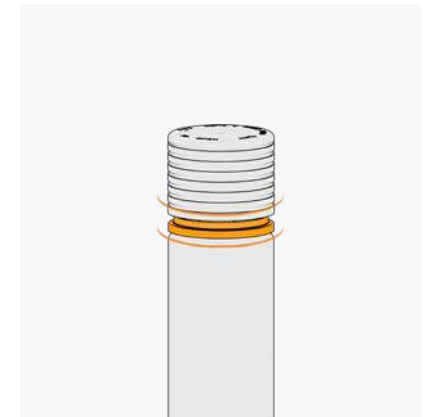

Straight / Tapered

Rotational Suspension Closure

Effortlessly set the closure in motion and close your bottle/container/tube with a closure that features a spring suspension that retracts the closure when it is pushed down. This feature provides a levitating experience while it turns.

BOTTLES

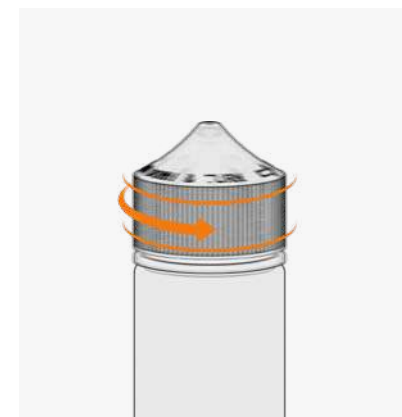

Dispensing / Beverage / Measurement

CONTAINERS



Containers with Liners / Thick Wall / Wide Mouth / Devices

TUBES

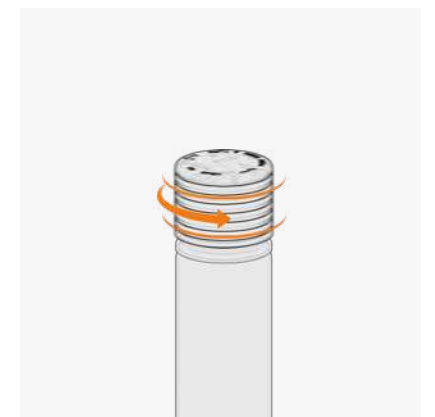

Straight / Tapered

Child-Resistant Closure

The container closure system incorporates a child-resistant closure designed to allow ease-of-use by senior adults.

BOTTLES

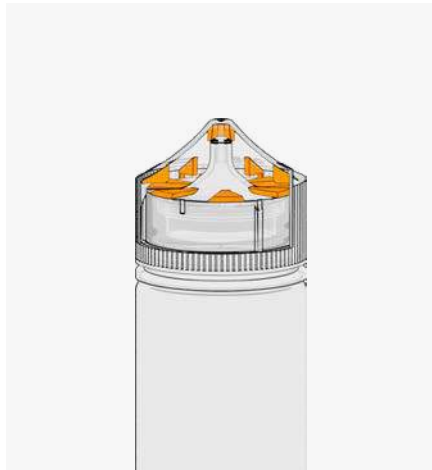

Dispensing



Beverage
(excludes Spiral® Shot Bottles)



Measurement

CONTAINERS



Containers with Liners / Thick Wall /
Wide Mouth



Devices

POUCH CONTAINERS



Single Compartment X3



Dual Compartment X2
(upper closure only)

TUBES



Straight / Tapered

Integrated Liner

The closure incorporates an integrated liner with the container neck, supporting odor-leaks from occurring.

BOTTLES



Measurement

CONTAINERS



Containers with Liners /
Thick Wall / Wide Mouth /

POUCH CONTAINERS

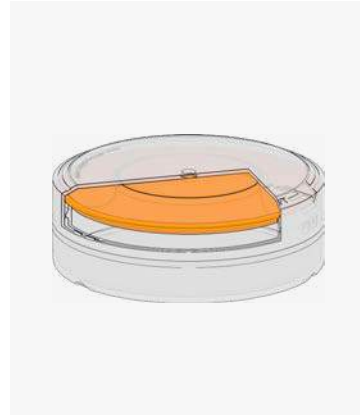

Single Compartment X3

TUBES



Straight / Tapered /
PopCap

Micro-Grip Diamond Surface

The precision milled micro-grip diamond closure allows for a comfortable and tactile experience providing more surface area to grasp and twist the closure.

BOTTLES



Beverage
(excludes Spira® Shot Bottles,
Spira® Bottles, Aviator® Shot Bottles)

CONTAINERS



Containers with Liners /
Wide Mouth / Device
(excludes Spira® Containers, Spira® XL Containers,
Spira® 510-Cartridge Containers)

POUCH CONTAINERS



Dual Compartment X2 /
High Capacity X1

TUBES



Straight / Tapered
(excludes Spira® Tubes)

Contoured Groove Surface

The precision milled contoured grooved closure allows for a comfortable and tactile experience providing more surface area to grasp and twist the closure.

BOTTLES



Beverage
(excludes Aviator® Shot Bottles, Aviator® Bottles)

CONTAINERS



Containers with Liners / Thick Wall /
Wide Mouth / Device
(excludes Aviator® Containers, Aviator® XL Containers,
Aviator® 510-Cartridge Containers)

TUBES



Straight
(excludes Aviator® Tubes)

Liquid Leak-Blocker

The liquid leak-blocker supports the dispensing nozzle tip internally to assist liquid leakage from occurring when the closure is closed. The liquid leak-blocker is shaped to the inner dispensing tip and is attached inside of the closure.

BOTTLES

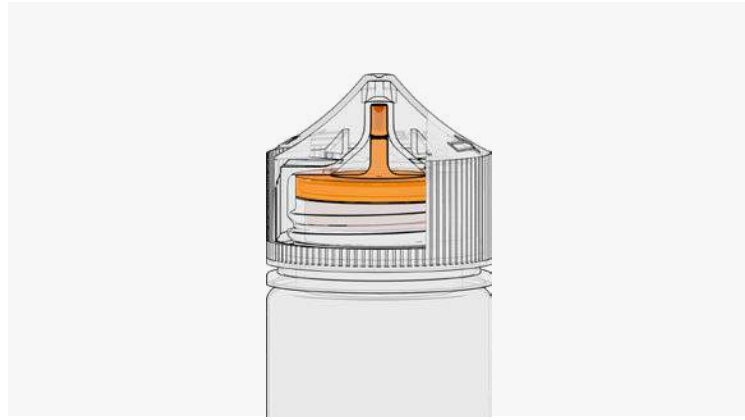

Dispensing
(excludes Unicorn Bottle® with Reducer)

Refined Nozzle

Dispensing nozzle reduces liquid discharge by applying a clever engineering technique on the nozzle's pathway that produces an equilibrium of pressures between both ends.

BOTTLES

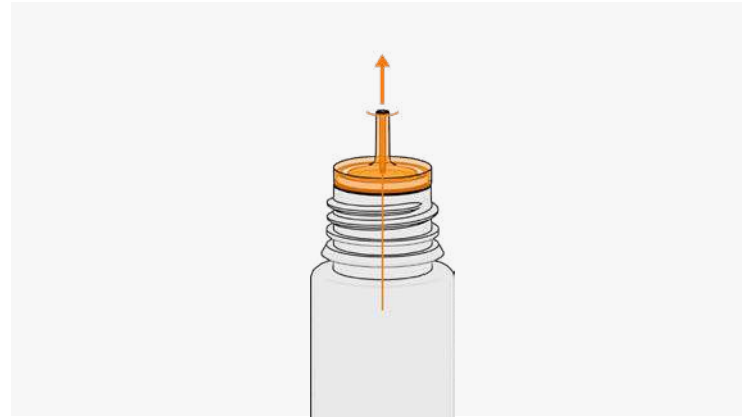

Dispensing
(excludes Unicorn Bottle® with Reducer)

Pinch A Drip, Squeeze A Flow

The nozzle and bottle jointly work as one unit to meticulously dispense fluid by the simple action of a pinch or a squeeze.

BOTTLES



Dispensing
(excludes Unicorn Bottle® with Reducer)

Convenient Smart-Fill

The nozzle and bottle jointly work as one unit to meticulously dispense the perfect amount of fluid by the simple action of a pinch or a squeeze.

BOTTLES

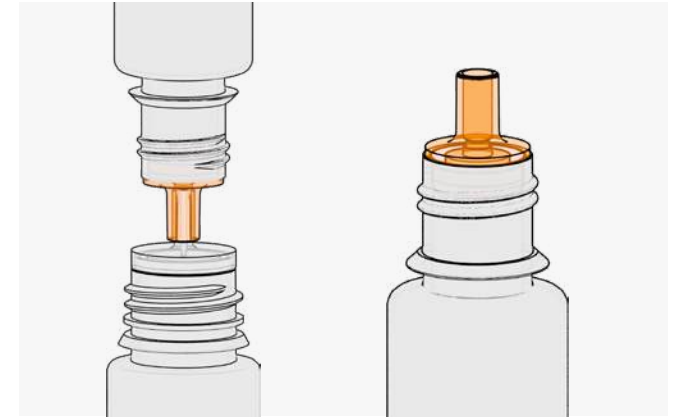

Dispensing
(Unicorn Bottle® with Reducer only)

Friction-Fit Closure

The SmartCap uses a friction closure that automatically creates a seal with the bottle neck, to support liquid leaks from occurring.

BOTTLES



Beverage

Lock-On Dosing Cup

The Dosing Cup is always at the ready as it is integrated into the closure system.

BOTTLES

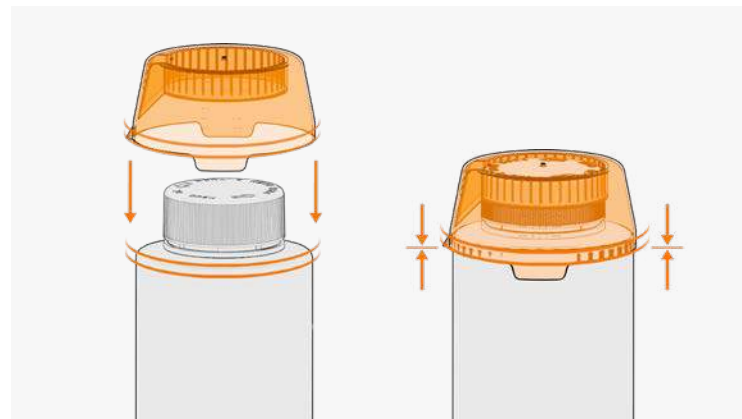

Measurement
(Aviator® Base Bottles only)

Dual Volume Dosing Cup

The Aviator® Base Bottle's Dosing Cup features two volume capacity reservoirs for measuring from 5 mL to 10 mL or 50 mL to 200 mL. The flexibility in measuring allows an easier way to custom mix and measure in one unit.

BOTTLES

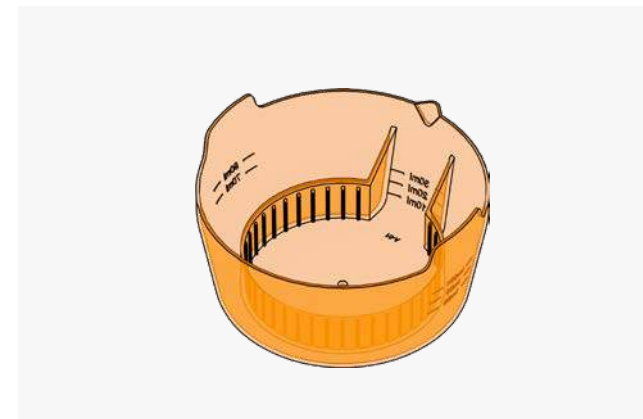

Measurement
(Aviator® Base Bottles only)

Slide On Dosing Cup

Spiral® Dosing Cups are engineered to seamlessly slide over the closure of Spiral® Bottles, creating a convenient, ready-to-use solution for on-the-go dosing

BOTTLES

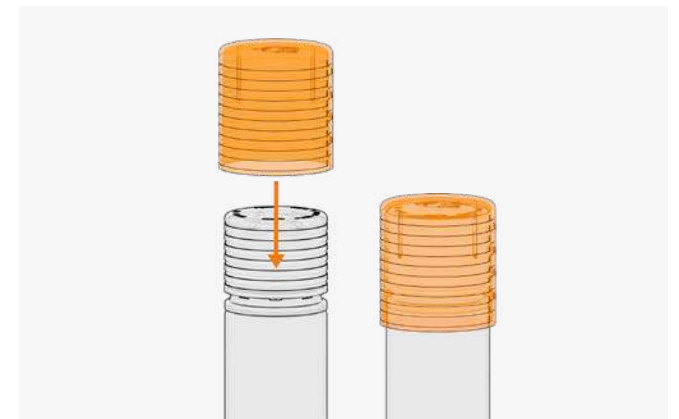

Measurement
(Spiral® Dosing Cup only)

Reinforced Wall

Spiral® Thick Wall Containers are designed with a reinforced outer wall, offering the sleek, elegant appearance of glass while providing superior durability.

CONTAINERS



Thick Wall

Universal 510-Thread Holder

The 510-Thread holder is integrated into the closure to hold cartridges in place in any orientation. (*510-Cartridge not included)

CONTAINERS



Devices

Storage Compartment

Convenient 50 g storage volume.

POUCH CONTAINERS



Single Compartment X3

Dual Storage Compartment

The integrated dual storage compartments are engineered to dispense pouches and store disposed pouches in a compact container.

POUCH CONTAINERS



Dual Compartment X2

High Capacity Storage Compartment

Stores up to 80 g or 100 g.

POUCH CONTAINERS

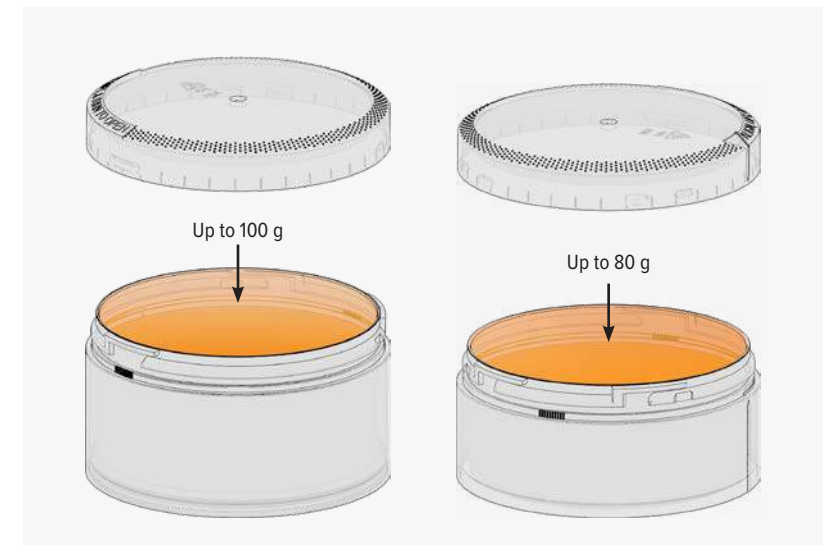

High Capacity X1



CUSTOM SOLUTIONS

CUSTOM FINISHES
 DIRECT PRINTING & LABELING
 POST-CONSUMER RECYCLED PRODUCTS

TAILORED TO YOUR NEEDS

Chubby Gorilla® offers custom branded packaging solutions to compliment your overall marketing strategy. Although packaging is perceived to improve brand identity, through our experience of assisting brands globally, we have learned that custom solutions can further elevate marketing efforts as part of a wider strategy. At Chubby Gorilla® we will work closely with you to offer a variety of special finishes tailored to fit your brand's identity. Our dedicated customization team is on-hand to help you realize this vision. It's worth noting that in a growing number of markets customization carries additional responsibilities and tests that will be required along with the potential costs that your brand will have to factor in. *We strongly advise keeping up to date with the ever-evolving legislation for packaging within the markets that you supply or intend on doing so.*

OUTER CLOSURE/INNER CLOSURE

*Custom finishes are not applicable to all products. Please consult a Chubby Gorilla sales representative to confirm customization options.



Mirror Plated
(1 Color Chrome)



Matte Metallic

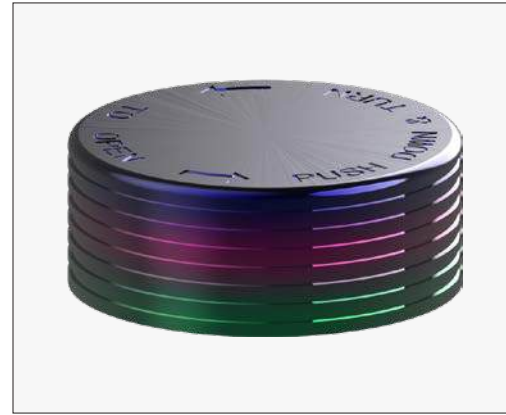

Ombre (3 Color Chrome)
(Outer-Closure Only)

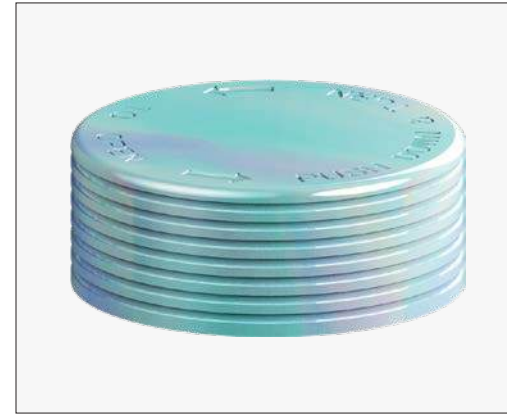

Iridescent Metallic
(Outer-Closure Only)

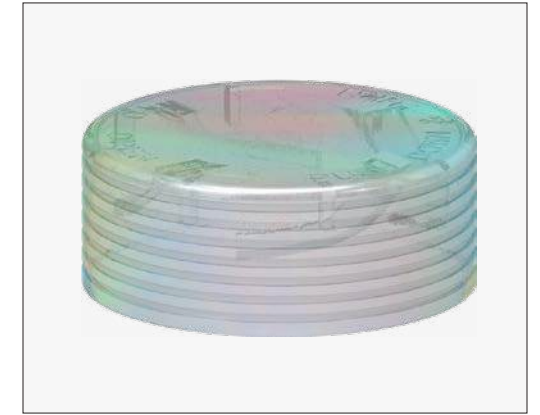

Clear Iridescent
(Outer-Closure Only)



Ombre (Matte)
(Outer-Closure Only)



Pearlescent



Coated Matte



Rubber Coating
(Outer-Closure Only)



Sandblast
(Outer-Closure Only)



Watertransfer
(Outer-Closure Only)



Standard Opaque



Standard Translucent



Standard Natural



Pearl Color (Uncoated)

BOTTLE/TUBE/CONTAINER

*Custom finishes are not applicable to all products. Please consult a Chubby Gorilla sales representative to confirm customization options.

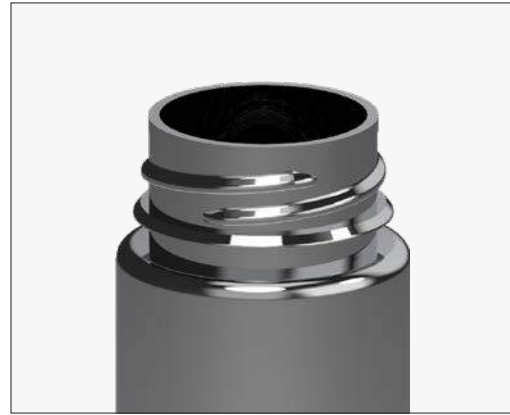

Mirror Plated
(1 Color Chrome)

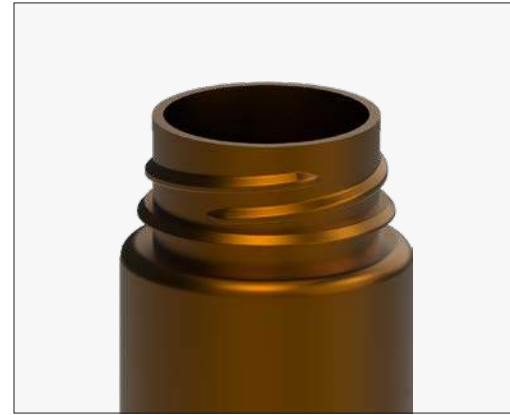

Matte Metallic

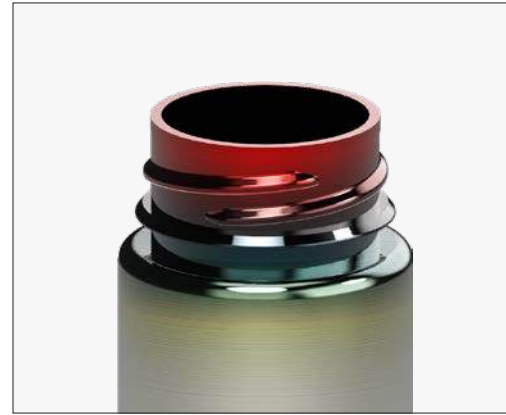

Ombre
(3 Color Chrome)



Iridescent Metallic



Electroplating
Window Cutout



Ombre (Matte)



Pearlescent



Coated Matte



Rubber Coating



Standard Opaque



Standard Translucent

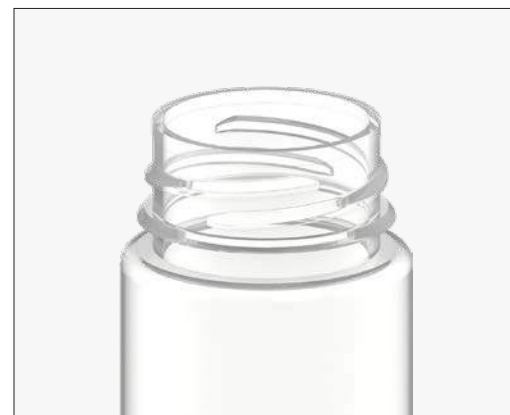

Standard Natural

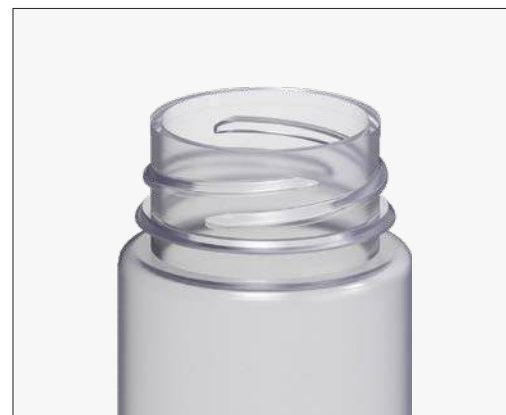

Matte (Uncoated)

PRINTING OPTIONS



Pad
(Outer-Closure Only)



Silk Screen



Heat Transfer
(Bottle/Container Only)



Phosphorescent



Spot-UV Print



Foil

LABEL OPTIONS

Direct label printing and label application available.



POST-CONSUMER RECYCLED PRODUCTS





SOCIAL RESPONSIBILITY

OUR ADOPTED GORILLAS



PINGA



KIGHOMA

WHAT WE DO

Chubby Gorilla® has been producing quality packaging for customers in over 100 countries. We consider our impact on people and the planet in everything we do. We continue to ask ourselves how we can make Chubby Gorilla® an even greater force for good in the world. To start we strive to support a balance of quality engineered, sustainable, and regulated products worthy of our brand and beneficial to our customers.



Through our membership with Ecologi's Climate Positive Workforce we are helping to offset our employee's carbon footprint and support climate positive projects.



Finally, since we are Chubby Gorilla®, we feel it is only right to support and protect our name sake. We've partnered with Gorilla Rehabilitation and Conservation Education Center (GRACE), to provide care for rescued Grauer's gorillas and work alongside the Congolese community to promote the conservation of wild gorillas and their habitat. With these efforts, it will help us towards our goal of social responsibility and sustainability.

ORANGE COUNTY, CALIFORNIA

DALLAS-FORT WORTH, TEXAS

AMSTERDAM, NETHERLANDS

HANGZHOU, CHINA

BANGKOK, THAILAND



A SPECIALTY PACKAGING COMPANY

CHUBBY GORILLA® IS A SPECIALTY PACKAGING MANUFACTURER, ENGINEERING SOLUTIONS FOR EMERGING INDUSTRIES ACROSS THE GLOBE.

GLOBAL HEADQUARTERS
CHUBBY GORILLA INC.,
4320 NORTH HARBOR BLVD,
FULLERTON, CA. 92835, USA
+1 (844) 365 - 5218

CHUBBY GORILLA INC.,
15860 CHAMPIONSHIP PKWY,
SUITE 300
FORT WORTH, TX 76177, USA

CHUBBY GORILLA EUROPE BV
URANIUMWEG 25,
3812 RJ, AMERSFOORT
NETHERLANDS

CHUBBYGORILLA.COM | DESIGNED IN ORANGE COUNTY, CALIFORNIA, U.S.A | © 2025 CHUBBY GORILLA INC. - ALL RIGHTS RESERVED

CHUBBY GORILLA, THE FIGURATIVE GORILLA LOGO AND OTHER MARKS ARE REGISTERED, PENDING OR UNREGISTERED TRADEMARKS AND/OR COPYRIGHTS OF CHUBBY GORILLA, INC. IN THE U.S. AND/OR OTHER COUNTRIES. THESE PRODUCTS MAY BE COVERED BY ONE OR MORE PATENTS OR PATENT APPLICATIONS, SEE WWW.CHUBBYGORILLA.COM/PATENTS

PRODUCT USE: MANY FACTORS BEYOND CHUBBY GORILLA'S ("CG") CONTROL AND UNIQUELY WITHIN USER'S KNOWLEDGE AND CONTROL CAN AFFECT THE USE AND PERFORMANCE OF A CG PRODUCT IN A PARTICULAR APPLICATION. GIVEN THE VARIETY OF FACTORS THAT CAN AFFECT THE USE AND PERFORMANCE OF A CG PRODUCT, USER IS SOLELY RESPONSIBLE FOR EVALUATING THE CG PRODUCT AND DETERMINING WHETHER IT IS FIT FOR A PARTICULAR PURPOSE AND SUITABLE FOR USER'S METHOD OF APPLICATION, INCLUDING BUT NOT LIMITED TO, DETERMINING WHETHER THE PRODUCT(S) PLACED WITHIN ITS PACKAGING SOLUTIONS ARE COMPATIBLE WITH EACH PARTICULAR PACKAGING SOLUTION.

WARRANTY, LIMITED REMEDY, AND DISCLAIMER: UNLESS AN ADDITIONAL WARRANTY IS SPECIFICALLY STATED ON THE APPLICABLE CG PRODUCT PACKAGING OR PRODUCT LITERATURE, CG WARRANTS THAT EACH CG PRODUCT MEETS THE APPLICABLE CG PRODUCT SPECIFICATION AT THE TIME CG SHIPS THE PRODUCT. CHUBBY GORILLA MAKES NO OTHER WARRANTIES OR CONDITIONS, EXPRESS OR IMPLIED, INCLUDING, BUT NOT LIMITED TO, ANY IMPLIED WARRANTY OR CONDITION OF MERCHANTABILITY OR FITNESS FOR A PARTICULAR PURPOSE OR ANY IMPLIED WARRANTY OR CONDITION ARISING OUT OF A COURSE OF DEALING, CUSTOM OR USAGE OF TRADE. IF THE CG PRODUCT DOES NOT CONFORM TO THIS WARRANTY, THEN THE SOLE AND EXCLUSIVE REMEDY IS, AT CG'S OPTION, REPLACEMENT OF THE CG PRODUCT OR REFUND OF THE PURCHASE PRICE.

LIMITATION OF LIABILITY: EXCEPT WHERE PROHIBITED BY LAW, CG WILL NOT BE LIABLE FOR ANY LOSS OR DAMAGE ARISING FROM THE CG PRODUCT, WHETHER DIRECT, INDIRECT, SPECIAL, INCIDENTAL OR CONSEQUENTIAL, REGARDLESS OF THE LEGAL THEORY ASSERTED, INCLUDING WARRANTY, CONTRACT, NEGLIGENCE OR STRICT LIABILITY.